

GND-1



Embrace the mayhem...

Explore circuit bending and controllable
chaos like never before

Rev 1.03 (c) Richard van Hoesel, Dec. 2024

INDEX

Key Features	3	PARAMETER EDIT screens	
Controls Layout	4	Edit index screen	21
Button+Encoder summary	5	Pitch	22
Quick Start	6	Drum 1	23
Essentials	7	Drum 2 / Word	24
Main Encoder	9	<i>MIDI Drum maps</i>	25
Core Parameters		MFO	26
1 Overview & Modulation	10	Bend 1	27
2 Morphing, Drifting, Scenes	11	Bend 2 / XPIfo	28
3 OSC level, ENV	12	Loop / Stereo	29
4 Drums	13	LFO / Tempo	30
5 Mix structure	14	ENV	31
6 Echo and mini Looper	15	Filter	32
MAIN PATCH screen	16	Post Filter / OSC	33
ALT PATCH screen	17	Mix / Echo	34
Morph Drift params	18	Expression mapping	35
Multimod, Scenes, Keybd	19	Modulation waveforms	36
MIDI setup	20	Trouble Shooting	37

Acknowledgements

Special thanks to Joe Manton for ongoing discussion, suggestions, and enthusiastic encouragement, without which the GND-1T would not be what it is today. Also to Hideaki Shirato and Joe for their unique contributions to some of the custom drum kits

KEY FEATURES

- Faithful emulation of the classic vintage Speak and Spell speech chip
- Digitally circuit bent and capable of so much more than in hardware
- Synthesis: formant / vowel / glottal / speech / rhythm / groove / circuit bent / glitch / complex oscillator
- Expansive / feature rich / sophisticated / deep architecture allows you to get inside the speech synthesis chip and explore this highly unique synthesiser (This ain't your dad's spelling machine)
- Around 150 real time parameters, with full stand-alone control and editing using the touch screen and encoders, or via MIDI over USB and 5-pin DIN (with user defined thru connectivity)
- MIDI USB HOST port for external controllers / keyboards
- Five GROUPS of (3+3) assignable encoders for instant 'live' parameter control via 30 virtual encoders
- Syncs to MIDI Clock with individually configurable PPQN scalers for Tempo, Drum and LFO rates, and loop length
- Automation capabilities that enable parameters to randomly DRIFT and MORPH between patches
- Full bidirectional MANUAL MORPH control between any patches with save option at any morph setting
- Powerful Expression Matrix allows every parameter to respond independently to modwheel, velocity, breath-control, after-touch, and a dedicated expression LFO (XPIfo) modulation block
- Unique modulation blocks that mix twin waveforms selected from over 30 different wave shapes and signal sources each
- Audio rate modulation of amplitude, pitch and speech filter using the "MFO"
- Touch Sensor, main rotary encoder, and MIDI note number assignable to expression matrix controllers
- Extensive randomisation possibilities with undo
- Ultra dynamic MIDI Rhythm Generator algorithm improvises drum grooves on-the-fly as it interacts with the synthesis engine
- Over a dozen Drum parameters, with the same extensive control as synth parameters and saved with each patch
- Drum note triggers can be sent to 40 unique built-in drum kits and external MIDI devices, and act as modulation sources
- Built in stereo overdrive, (fat) resonant Post-Filter, and classic echo / looper functions
- Full stereo 44kHz analog and digital USB Audio I/O
- Store up to 1000 presets with seamless preset switching and morphing

Glitch - 1 T

Glitch and Drum Touch

Post Filter Cutoff
ALT = Echo Volume

Stereo 1/4" Audio out

USB host (controllers)

USB midi and audio I/O

DC 9V center +

P1-3 and [ALT] P1-3 are 6 assignable* parameter control encoders

P1 controls DRIFT depth when DRIFT is active

MIDI 5P DIN out

MIDI 5P DIN in

Touch Screen

Master level out
ALT = PF (synth) scaler
XPress = Drums scaler

Stereo Aux line in (3.5mm)

Main Encoder (clickable)

Phones out

See next page for a summary of the touch button and main encoder functions

Expression (XP) touch button

Patch page / ALT touch button

Parameter EDIT page touch button

* Five groups of assignments are available for a total of 30 virtual encoders



Touch Button & Main Encoder Summary

Expression touch sensor (e.g Breath) Show main Patch screen Show Param Edit Screens

Metal Touch buttons:

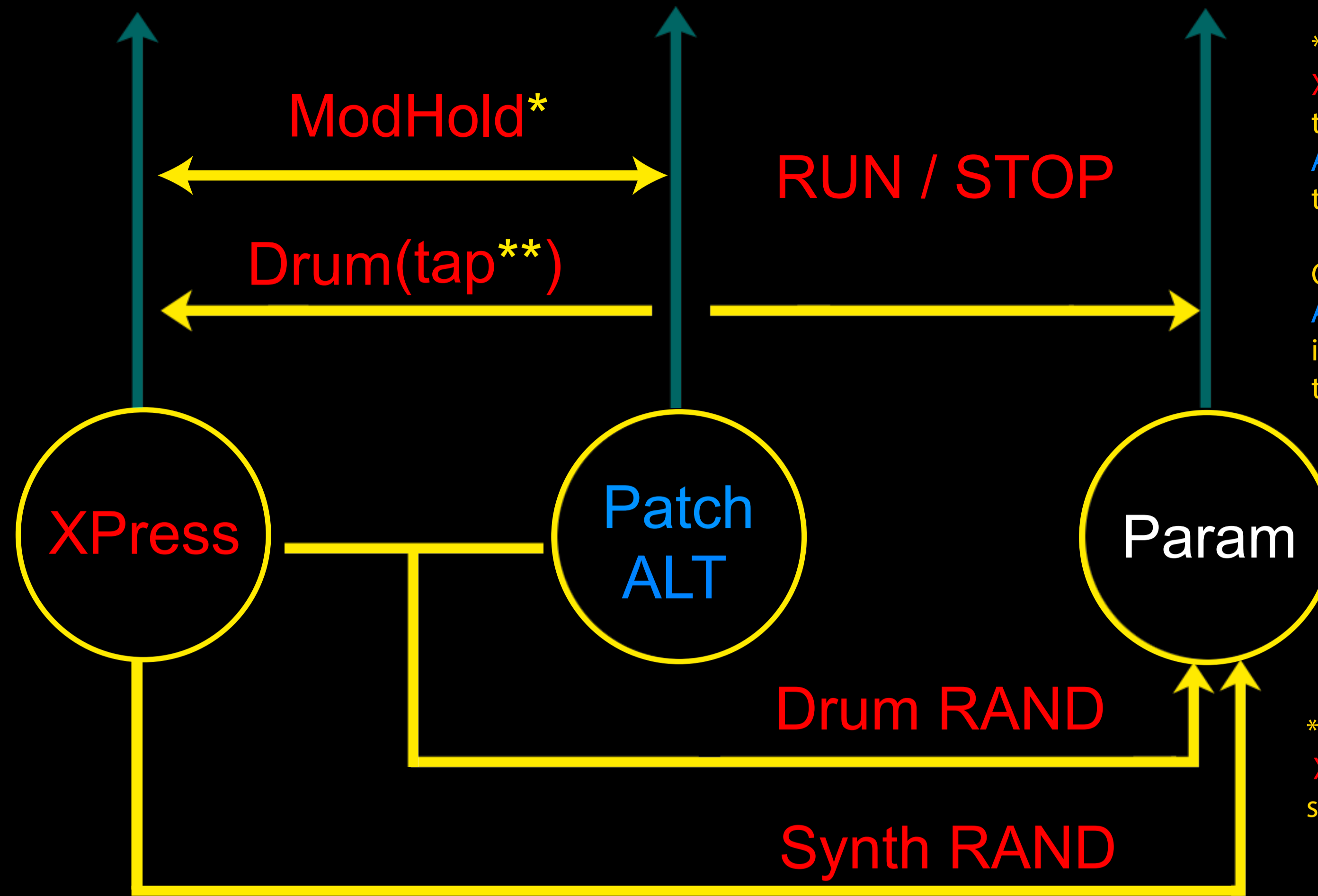

* On the main *PATCH* page XPress before ALT includes touch effect during modhold ALT before XPress disables touch effect during modhold

On any other page ALT before XPress modhold is not available, and instead toggles drum mute

** On any page, ALT hold + XPress tap with RUN off starts RUN drums only

Level out pot

button	pot sets
no touch	All audio levels
XPress	Drum scaler
ALT	PF (synth) scaler

MAIN ENCODER functions from Any page: * except SCENE and DriftBuffer buttons (see P9)

- ALT + click * = revert last PostFilter or P 1-3 encoder & release its exclude
- XPress + click = null main encoder and touch sensor controllers
- ALT + XPress + click* = mod/loop hold mode

Long hold = release excludes

Turn any P1-3 enc to cancel release and adjust P1-3 GROUP

- ALT + hold = clear echo
- Xpress + hold = show XP mapping page

Patch page: * EchoFreeze functions not shown (see page 15)

- click = SAVE / DELETE menu
To cancel Save & Delete click encoder again
- turn = enc assigned controller value (e.g. modWL), unless:
patch # if patch-select mode on manual morph cntrl if morphing
- ALT + turn = patch # (click to cancel)
- ALT + XPress + turn = touch scaler

Parameter Editing:

- click * = undo / revert / null & for any pot param release its exclude
- hold + tap screen
For any switch type parameter release its exclude
- turn = selected pot parameter val

QUICK START

The GND-1T requires a **center positive 9V DC** power source. Recommended current rating is 500mA or more, especially if connecting a higher draw MIDI controller to the USB-HOST port. A small angled stand is recommended for desktop use

On power-up the main **PATCH SCREEN** shows the active Patch, which is the last one saved. In total 1000 patches (0-999) can be stored. Via external MIDI these are accessed as 10 banks of 100

The GND-1T comes with a number of factory presets to facilitate immediate auditioning of some of its abilities

1. Press **RUN** to hear the patch. Press again to stop the patch

2. Press the **patch number** or tap the metal Patch button to highlight the patch number and change patches with the main encoder. If RUN is on, you will hear each patch in turn. Empty patches show as “- -” and the user definable Template params are loaded

3. To **avoid hearing the intervening patches** when changing to a more remote one, hold down the metal ALT / PATCH button while turning the encoder. This also works without first highlighting the patch number

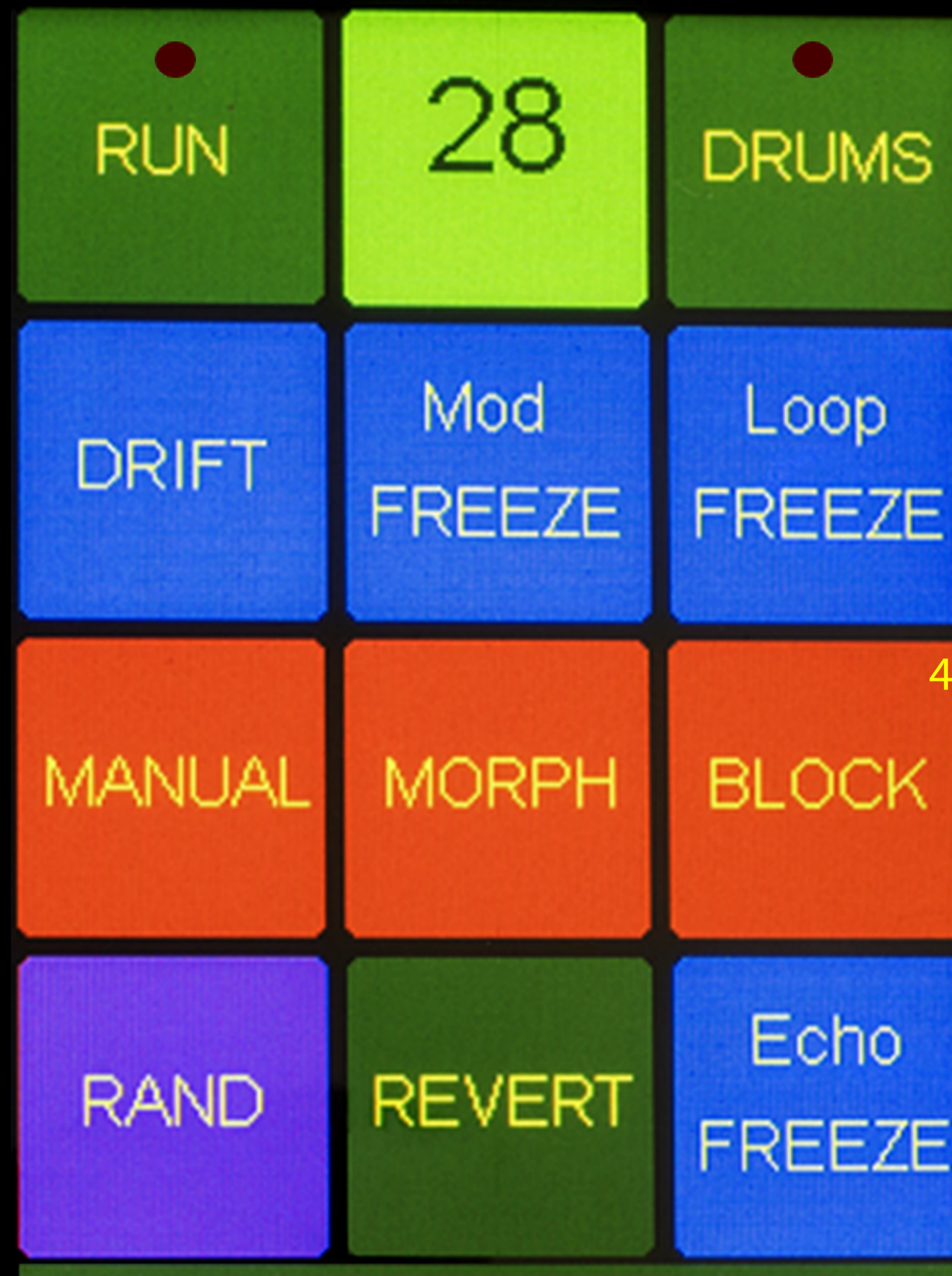

toggle
button

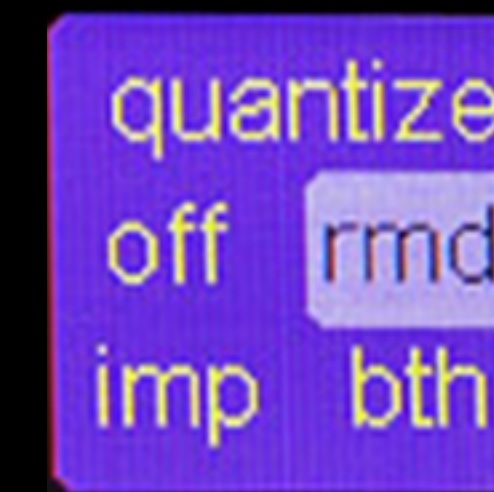

multi position
switch

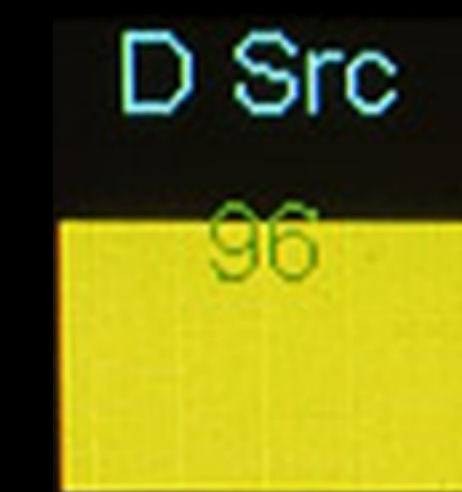

pot
(use encoder)

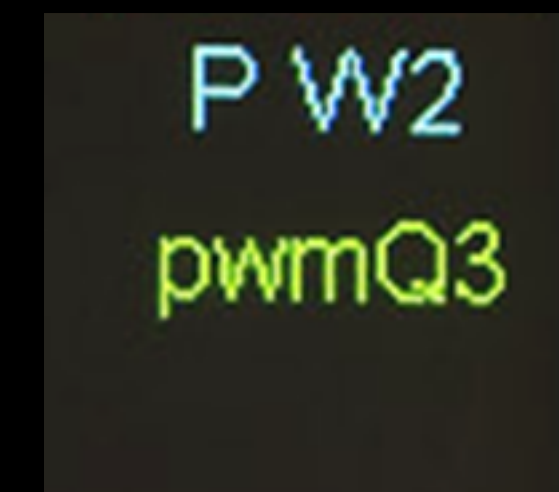

text pot
(use encoder)

4. If the patch has active drums, the **DRUMS** button will be lit. Tap it to toggle drums on/off. If both MIDI and internal drums are active, a blue led will light on the DRUM button during drum events. A red led indicates only MIDI, and yellow only internal. ALT+ tap XPress without RUN starts solo drums

5. Press **RAND** to randomize parameters (you can leave RUN on). Press **REVERT** to recover the original patch. Press **DRIFT** for slow continuous randomization where P1 sets DRIFT depth. Try the three **FREEZE** functions

6. With RUN on, toggle **MANUAL** morph on. Hold the metal Patch button and select a target patch with the main encoder. After selection the encoder acts as a manual morph control between the current parameters and selected target. Press MANUAL again to exit morphing and retain the morphed param values

7. Hold the metal Param button down to go to the parameter edit index page and select the DRUM2 / **WORD** page. Press ALT+ INIT (bottom right) followed by RAND WORD to play random words. Create classic circuit bent speech sounds using ALT+ RAND GLITCH or apply more bends on the BEND pages. Adjust Loop, Pitch and Tempo parameters on their respective edit pages

Essentials 1

To go to the last used **Parameter edit page** tap the metal Param button or hold it down to show the edit index page

To return to the main **Patch page** tap the metal ALT/Patch button

The GND-1T is controlled using its touch screen*, three metal touch buttons, and multiple encoders. At power-up it shows the **MAIN PATCH page** and loads the last saved patch. Hold the metal PATCH / ALT button to show additional functions

* The GND-1T uses a resistive touchscreen that requires a slightly firmer touch if using the flat of your finger. For a lighter touch response, use more of your fingernail

To start/stop the audio, press **RUN** from the MAIN PATCH screen, or touch the metal ALT + Param buttons from any page. Hold the ALT button and rotate the main encoder to **select a new patch** (click to revert). Or tap the ALT button or patch number (highlights) to select patches with just the encoder. Tap again to exit. Empty patch slots show as “- -” and load a user definable patch Template (see page 17)

If any patch parameter (or one of its 5 XP matrix values) is manually adjusted, the parameter and its XP values are **EXCLUDED*** from further MORPH, DRIFT, RAND and MULTI-MOD effects. To release a pot parameter** from exclusion, select it on its Param Edit page and click the main encoder. To release a switch type parameter hold the encoder and tap the screen button. **To release all parameters use a long press on the main encoder from any page**

* This stays in effect (even through patch loads) until manually released, or until a Scene is loaded that reinstates its own exclusions

** PostFilter/Echo, and pot parameters assigned to P1-3 encoders, can also be released by using the ALT+ main encoder click to revert the last adjusted encoder

To morph from the current patch to a new one, activate the **MANUAL** or **MORPH** screen-button before selecting the new patch. In **MANUAL** morphing the main encoder becomes the morph control. In (Auto) **MORPH** mode the morph occurs automatically during RUN or MIDI note on events. **BLOCK** morphing continually morphs between multiple patches in accordance with the parameter settings available via [ALT] + MORPH. Morphing can be gradual, or instant if a **STEP** mode is activated. Pause MORPH and BLOCK morphing by pressing **MANUAL**.

DRIFT applies continual slow varying randomization, according to its depth and rate settings. Switching DRIFT off retains the Drifted values using a Drift offset buffer that can be cleared, saved or recalled (see p11 & 18). If MORPH or BLOCK are enabled (with **MANUAL** off) the DRIFT button becomes momentary action to allow brief Drift adjustments

On the main patch page toggle the **DRUMS** button to **enable or mute DRUMS** (or hold ALT + tap XPress briefly on other pages). Patches are saved & recalled with this status. To instead preserve current DRUM mute, and internal Kits on patch load/morph, use ALT+DRUMS to set **GLOBAL DRUMS**. From **STOP**, hold ALT + briefly tap XPress on the PATCH page to **run just the drums**. This mode allows external MIDI notes to play the Patch sounds without stopping drums between notes

Complete setups (including morph parameters) containing the current state of the GND-1 can be saved and recalled as **SCENES** (P11, 19)

Essentials 2

To see the current firmware version, hold the metal PATCH button during power up

To activate DUAL MONO OUTPUT mode, which sends the PF/synth to the L channel (tip), and non-PF Drums to the R channel (sleeve), hold both PATCH and XPress during power up

To **edit the parameters** of the current patch, touch the metal PARAM button. Parameters are layed out in 12 functionally grouped pages. A brief touch takes you to the most recently edited page, or a longer hold shows the INDEX page to select an edit page. Tap the metal PARAM button to toggle between the current edit page and the INDEX. To edit a parameter, tap it on the screen. Buttons will toggle, and pots (and “text-pots”) respond to main encoder changes

To **assign a (pot) parameter to one of the P1-3 encoders**, hold the parameter on the screen and turn the desired encoder. To assign to the [ALT] P1-3 encoders, do the same while also holding the ALT button. To stack up to 3 parameters for any P1-3 or [ALT] P1-3 encoder, add in the metal PARAM button for the second and third parameters. All assignments are automatically saved. A complete set of all the P1-3 and [ALT] P1-3 assignments is called a **GROUP**. To switch to any of the 5 available groups, hold the main encoder and turn any P1-3 encoder*. The Mod FREEZE button shows the current GROUP in its top left corner

* The pop-up dialog shows the parameter(s) assigned to the encoder being turned for each GROUP. Changing GROUP cancels any pending excludes release

To **SAVE*** or **DELETE** a patch, from the MAIN PATCH page click the main encoder to show those options. This also shows SAVE Globals and SAVE Template options (P17). Click the encoder again to cancel SAVE mode

* Save is only allowed to the current patch, or an empty slot indicated by “- -” under the patch number. To overwrite another existing patch, first delete it

Nearly all parameters in the GND-1T are patch specific and are saved and recalled for each patch number. There are a small number of additional **GLOBAL** parameters, including all the parameters on the MORPH-DRIFT-params and the MIDI drum-map pages. Global parameters that show a “G” there or elsewhere indicate that although they are global, they can nevertheless be expression mapped and assigned to P1-3 encoders. The SAVE Globals option excludes MIDI drum maps and Drift offsets, which have their own save functions. Saved globals are reinstated on power up

The **main encoder**, and metal **XPRESS** button can act as expression controllers (modWL, and breath-control by default). Hold ALT+XPress and turn the encoder on the Patch page to set a touch **scaler** to moderate touch XP strength. The scaler affects all patches and is set to 1 on power up. The XPress button can also be assigned to various other functions on the **XPMAP** page (hold both XPress + encoder)

The **Level out pot** sets all analog and USB audio output levels when no buttons are held, and provides distortion free audio at its maximum level. Hold ALT when turning it to scale down only the PostFilter (synth) output, or XPress to scale down the drums. Hold Param to dim the screen brightness. The PF and Drum scalers (and screen brightness) are not affected by any parameter settings or patch changes, and are reset to 1 on power up

MAIN ENCODER

The **MAIN ENCODER** allows patch selection, parameter value editing, and many other functions when combined with the metal touch buttons (see also page 5)

A **short click** of the encoder on most pages nulls or restores the edited parameter. On the PATCH page it shows the SAVE options

On the main PATCH page

- *turn* the encoder with ALT held down to **change the patch**, or if block morphing, relocate the Block start
- *turn* it on its own* to alter the **controller** value it's assigned to (modWL by default), or if morphing is active, adjust the balance between the two patches being morphed
 - * if patch-select mode is on (patch number is highlighted) patch number changes instead
- *turn* with both ALT+XPress held down to adjust the global **touch sensor scaler** (initialized to 1.0 at power up)
- *click* to show the patch **SAVE*** and **DELETE** options, including **SAVE Globals**** and **Template (P17)**
 - * Saving is only allowed to the currently loaded patch when not morphing, or an empty patch that shows as "- -". Click the encoder again to cancel SAVE / DELETE
 - ** Global (non patch specific) saved parameters include the MORPH+DRIFT params, USB in & PF, Touch Sensor Attack/Release, and Pitch Bend +/- range
Global parameters that show a "G" on the screen can be XP mapped and assigned to P1-3 encoders
- when **ECHOFREEZE** is active, the encoder is also used to set Punch or Dub modes for looped audio (see page 15)

On the PARAMETER EDIT pages

- *turn* the encoder to change the value of the selected parameter on the screen
- *click* the encoder to restore the selected parameter to the value it had when last selected and **release its exclude***
 - * For button / switch parameters, hold the encoder and tap the screen button to release its exclude

On ANY page*

* except SCENE and DRIFT BUFFER select pots:

click = LOAD, ALT+ click = SAVE (press screen button), XPress+ ALT+ click = DELETE (press screen button) See P18 & 19

- ALT+ *click* reverts the last P1-3 encoder change to the assigned parameter's saved value and **releases its exclude**
- XPress+ *click* nulls the encoder and touch sensor controller values (modWL and breath control by factory default)
- ALT+ XPress+ *click* toggles between modhold (power up default) and loophold functions
- A **long encoder hold** releases **all parameter excludes** from morphing, drifting, mult-mod, and randomization commands
- ALT+ **long hold** clears the Echo buffer (page 15)
- XPress+ **long hold** shows the XP mapping page with matrix values for the most recently selected edit parameter
- A **long hold+** turning any P1-3 encoder selects one of the five available P1-3 **GROUPS** (page 8)

CORE PARAMS 1

Overview & Modulation

The GND-1 is based on an accurate emulation of the **speech synthesizer chip** found in the classic vintage Speak & Spell game. As it speaks, the chip reads small fragments of information about voice (oscillator) level and pitch, and the speech filter resonances from **ROM** memory. The rate at which it does this is the **TEMPO** parameter in the GND-1T, and sequences of those fragments form a word or LOOP. When the GND-1T is in **SPEAK** mode (WORD PAGE), the data from the ROM is retrieved from known word locations, otherwise it's random, and a whole new range of sounds is created. The circuit **BEND** parameters interfere with the interpretation of the ROM data. **PITCH** scales the ROM pitch contours, and **FILTER** modifies the speech resonances

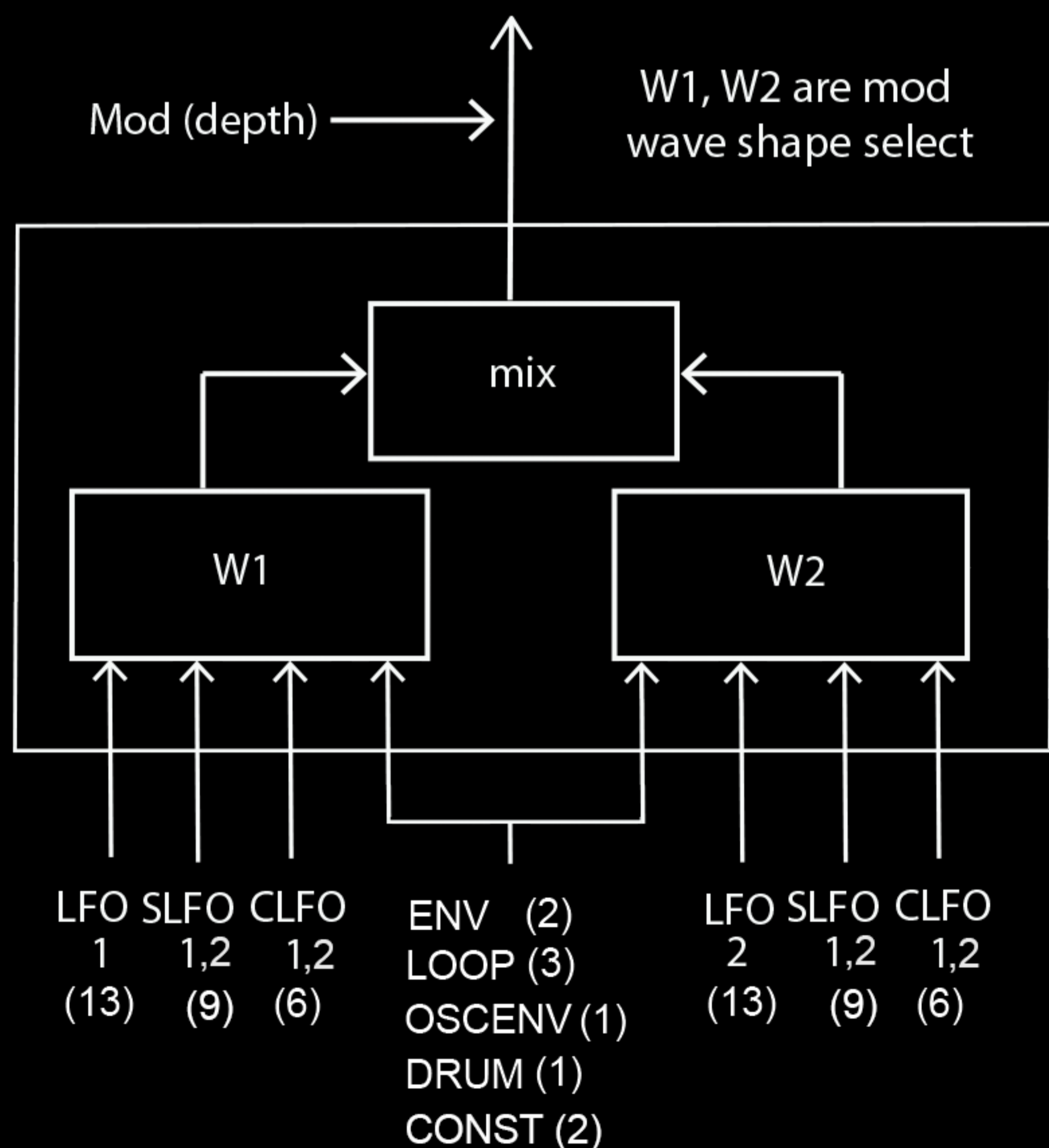

Twin-waveform (W1,W2) modulation block structure. Seven blocks for Pitch, Filter, Loop-length, Bends, Drums, Post-Filter, and XPLFO. Some are also shared with other params

A large number of synthesizer parameters have been added around the speech synthesis core in the GND-1T. Key parameters can be modulated by **twin waveform modulation blocks** that mix waveforms derived from two LFOs, two slow SLFOs, and two chaotic CLFOs, as well as AHDSR / ENV, LOOP, OSCENV, DRUMS, and two constants. One of the mod-blocks is used as the XPLFO expression controller

In addition, *every parameter** in the GND-1T has five associated values in the **EXPRESSION (XP) MATRIX** that determine how much the parameter is affected by MODWHEEL, VELOCITY, BREATH-CONTROL, AFTER-TOUCH, and XPLFO. Setting those values is called **expression mapping**. To set them, hold the parameter on the edit pages and tap the metal XPRESS button to go to the XP mapping page. Or hold XPress and the main encoder together to map the currently selected parameter. The XPRESS touch sensor by default acts as a breath controller and the main encoder as a modwheel. Both can be re-assigned on the XPmap page

* Except simple switches (magenta), MIDI channel / thru / drum-notes, and most morph automation parameters

PITCH, (Speech) FILTER and AMPLITUDE can also be modulated at audio band frequencies using the **MFO** (mid freq oscillator) modulator. It includes OSC-sync and fine-tuning that allow interesting sonic interactions between the OSC and MFO frequencies, and can itself be modulated using the W1/2 signals from the LOOP mod block

CORE PARAMS 2

Morphing, Drifting, Scenes

To morph automatically from the current patch to a new one (during RUN or MIDI note events) activate MORPH and select the target. Turn the main encoder at any time to make manual adjustments. To morph continually between multiple patches, starting with the current patch, press BLOCK*. Relocate the block start patch at any time using ALT + encoder. Set the BLOCK and automation parameters on the MORPH+DRIFT params page (hold ALT+ press MORPH). For gradual parameter morphing leave StpMode OFF, and set Morph and Wait times along with Block size. For instant STEP parameter changes between patches, set StpMode to ON or ONsync, and set Step Rate instead of MorphTime. Or set StpMode to KeyStp or KeySnc to step on MIDI note-on events. StepRate can be expression mapped and assigned to P1-3 encoders. Automation can be paused at any time by activating MANUAL. See SCENES (below) to save/load your favourite BLOCK morph configurations .

* See page 13 for a description of Drum selection options during BLOCK morphing

The DRIFT function on the Patch page slowly randomizes current patch parameters. Set the Drift rate and depth on the ALT+ MORPH params page, or adjust depth using P1 whenever DRIFT is on. Turn off DRIFT to stop further Drift changes, and retain* the drifted sound. In MANUAL morphing mode the Drift button operates the same way as when not morphing. For MORPH or BLOCK morphing it becomes momentary action to allow shorter Drift changes**. The acquired Drift offsets are placed in a buffer that can be cleared (ALT+ DRIFT), temporarily stored (DRIFT+ tap Patch ▼) or recalled (DRIFT+ tap Param ▲), or permanently stored or recalled via the Drift Buffer pot on the ALT+ MORPH page. Select that pot and turn the encoder to select a Drift Buffer, click the encoder to LOAD***, ALT+ click to SAVE to that buffer (tap screen), or XPress+ ALT+ click to DELETE it (tap screen).

* Non morphed patch changes clear the drift offsets. To preserve drift offsets with patch changes, activate MORPH using STEP mode. Or use MIDI notes to change patches by setting Note XP to a patch mode (P35). Saving a drifted Patch stores the sound as you hear it, with the drift offsets added to all parameters to allow for Drift being cleared on patch loads. REVERT or reload the patch after SAVE to see the updated patch parameters with the Drift buffer nulled.

** When MANUAL is off. To use these modes with continuous Drift changes, enable DRIFT before MORPH/BLOCK. Or once morphing, enable MANUAL, then DRIFT, and then disable MANUAL

*** Load any of the permanent drift buffers to reversibly audition up to 128 variations of the current patch or morphing block

SCENES are super-presets (0-127) containing the current state of the GND-1T, including BLOCK* Morphing parameters, Drift Buffer values, Drum Mute*, Touch Attack/Release, and any manually adjusted parameters (with morph exclusions). Select a Scene using the SCENE pot on the Multi-SCENE-Keybd page. Click the main encoder to LOAD, ALT+ click to SAVE (tap screen) and XPress+ ALT+ click to DELET (tap screen). “#” next to a Scene number indicates it exists, and “@” that it was last loaded

* If BLOCK is enabled when saving the Scene, it is automatically re-enabled on Scene load. To save individual Drum Note Mutes, MUTES must be enabled (P25) when saving the Scene

One of the most powerful features of the GND-1T is its ability to MORPH complete parameter sets from one patch to another while the audio is playing. This can be done under full bidirectional MANUAL control using the main encoder, or automated. Partly morphed patches can be saved at any time as new patches, without disrupting the morphing state between the original patches

To manually morph between the current patch and a new one (the target) activate MANUAL on the PATCH page and select the target using [ALT] + encoder*. Once selected, the encoder becomes the manual morph control. Additional new targets can be selected from any morph state

* or hold MANUAL and tap Param to increment, or Patch(ALT) to decrement. Or press RAND Target to morph to random parameters

CORE PARAMS 3

OSC level, ENV

The **OSCGAIN** parameter (PostFilt / OSC page) and optionally **OSCENV** (ENV page) modify the oscillator level before it goes into the speech FILTER. When OSCENV is “Off” the raw levels from ROM are scaled by OSCGAIN only. Set this to 64 for the original speech chip levels. Set to 0 to eliminate the Synth signal from the audio, but keep sending ROM information to the Rhythm generator and allow AUX input signals to be heard

Enabling **OSCENV** causes **OSCILLATOR AHD (ATTACK-HOLD-DECAY*)** smoothing of the ROM levels as they are updated at TEMPO rate. When a new OSCGAIN-scaled ROM level exceeds the current OSCENV value, ATTACK sets the rate at which OSCENV increases. Otherwise DECAY sets the rate of decrease to the new level. Use the AHD->0 option to decay to 0 rather than the new ROM level

* Although OSCENV and AHDSR ENV share the same ATTACK, HOLD and DECAY parameters, their envelopes operate independently

More complex options add Loop FREEZE or Mod FREEZE during the AHD cycle, or continuously retrigger at AHD rates between TEMPO triggers. Be aware that by design the OSCENV freeze modes disrupt the normal progression of loop or modulation updates. Check the Patch page Mod FREEZE and Loop FREEZE buttons for “^” indicators showing these modes are active

The non-linear interaction between TEMPO, ROM levels, OSCGAIN, AHD times and ATTACK-DECAY MODULATION can produce many interesting OSCENV results. Usually AHD modes are best suited to lower TEMPO rates to avoid overlapping the AHD cycles too much

The speech FILTER output is summed with the **AUX** input and sent to the **POST-FILTER (PF)**. The PF output envelope depth is set by **AMP ENV** which acts as a mixer between a rectangular envelope at min, and the **ENV** signal at max. For MIDI Note-On events while RUN is off, or if ENV triggers are active (ENV page), the full **AHDSR** is used to set the shape of the ENV signal

For RUN activation without active ENV triggers, only ATTACK and RELEASE times are applied and the ENV otherwise remains at unity to preserve good loop levels. To instead trigger a full AHDSR cycle on RUN, turn on RUN T on the ENV page

Note that all signals sent to the PF (including AUX in) are co-modulated by the output envelope

CORE PARAMS 4

Drums

The speech chip data and audio signals are used by the GND-1T's unique multi-parameter **rhythm generator** to improvise **DRUM** signals on the fly as it dynamically interacts with the speech ROM data and audio signals. Unlike conventional drum programming, the DRUM pages on the GND-1T act just like the other synth parameter pages with pots and switches to shape the rhythm sequences that are generated. There is a dedicated modulation block that can be used to alter trigger density, rate, pattern and kit parameters, and all parameters can be linked to the expression matrix. To randomize drum parameters from any page, hold both XPress and ALT buttons, and tap Param

The rhythm generator activates user specified **MIDI notes out on channel 10** and/or the **GND-1T internal DRUM KITS**. Set the output method using the D out switch on the **MIDI KITS** page: From any page, hold down Param until the INDEX screen appears and with Param still down, tap the DRUM2 button. The MIDI KITS page allows editing of the drum notes for each of the three MIDI drum maps. When MUTES is active, each drum note button acts as a **global mute of that trigger** for both MIDI and internal drums. Internal drum Kits are selected* on the DRUM2 page. The parameter KIT MODULATION DEPTH on that page allows modulation between the main drum kit and two additional kits, using the DTmix (drum trigger mix) waveform. For MIDI drums, the mod maps are the two unselected ones. For internal Kits they are specified on the DRUM2 page as kit m1 and m2

* Selection options include 40 drum kits, two RANDOM modes that randomize the kit for each new drum note (RAND2 excludes pitched kits) , and 3 user defined kits (see MIDI ref)

The **D SRC** parameter on the DRUM1 page determines the source of the drum events. It acts as a mixer between speech chip ROM or LFO events at minimum, and post-filter mixed audio (including USB and echo) at maximum. Select whether ROM or LFO events are used using the Dsrc=0 button. **DTRIG** sets the amount of drum trigger activity and alters drum selection within kits, with higher levels corresponding to denser sound. **D RATE** sets the base maximum trigger rate, but the actual rate will depend on its interaction with the D SRC signal. **D PAT** changes the patterns generated by the algorithm, and **IMPROV** allows further improvisation and randomization to be applied. D RATE mod and IMPROV can be optionally quantized

To **enable or disable** drums, toggle* the DRUMS button on the PATCH page, or hold ALT and briefly tap XPress on other pages. When **RUN is not active** the latter sequence starts the **drums on their own**. External MIDI notes can be played in this state to activate the synth while the drums keep running in between notes. The drum parameters, Kits, and enable-status (but not individual note mutes) are stored and recalled along with each patch. To retain current drum Kits and enable-status throughout further patch changes, use ALT+DRUM on the main PATCH page to toggle **GLOBAL DRUMS**

* When morphing or drifting, this action excludes Drum enable status from following further morph/drift changes. Release it by holding the encoder and tapping the DRUMS button

When **morphing** you can **exclude drum parameters** (including kits) from morphing by setting the **Order** parameter on the MORPH+ DRIFT params page to S-Drm (sequential, exclude drums) or R-Drum (random order, ex. drums). To use drum parameters from a different patch to the BLOCK start patch, select the Patch with the desired drum parameters before activating BLOCK. Then use [ALT]+ encoder to relocate the start of the block

CORE PARAMS 5

The output of the speech FILTER is summed with the AUX input before optionally being sent to the OVERDRIVE* (0 = bypass). USB audio and DRUM PF mix signals can be added on the MIX page. Together these signals form the input to the POST-FILTER and output amplitude ENV shaping stage. The remaining proportions of the USB and DRUM signals not sent to the PF are combined with the PF output for stereo output, and echo input selection

* OscGain values below 64 reduce the effect of the overdrive as well as lowering oscillator signal levels

Mix structure

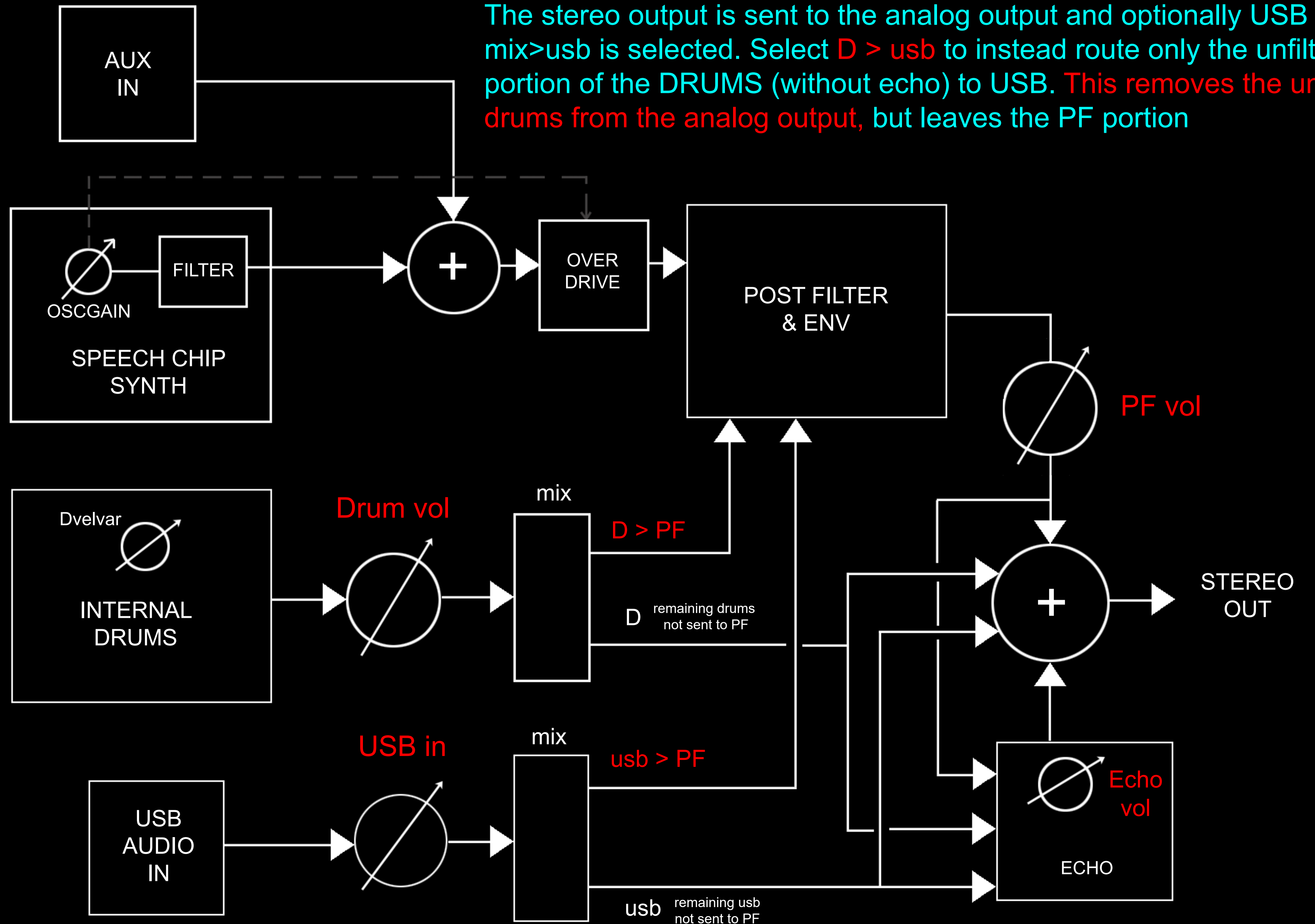

The stereo output is sent to the analog output and optionally USB when **mix>usb** is selected. Select **D > usb** to instead route only the unfiltered portion of the DRUMS (without echo) to USB. This removes the unfiltered drums from the analog output, but leaves the PF portion

CORE PARAMS 6

Echo and mini Looper

The **ECHO** effect in the GND-1T spans from a few tens of ms to about 2.5 seconds. ECHO Volume, Delay Time, Repeats, and input selector are adjusted on the MIX page. ECHO Volume is also set from any page using [ALT] + Post Filter Encoder. Activate **ECHO FREEZE** on the main PATCH page to freeze the current echo buffer. The echo loop keeps playing while the synth can be used in the usual way, selecting other patches etc. ECHOFREEZE at longer delay times can be used as a mini LOOPER with Punch and Dub options

ECHO parameter settings are stored and recalled with each patch. To override this and use the current echo parameters while recalling or morphing patches, turn on **GLOBAL ECHO** on the MIX page. GLOBAL ECHO also applies when ECHO FREEZE is enabled*

* But not when ECHO FREEZE is activated automatically by the expression matrix values for the XFRZ T parameter (BENDS2 page) and XfFRZ mode is set to echo

To facilitate loop construction when ECHO FREEZE is used as a mini **LOOPER**, first set the delay time and echo volume. It may be preferable to switch RUN off so only the ECHO LOOP is heard. Optionally clear the echo buffer using ALT+long hold of the main encoder. On the main PATCH page, select **PUNCH** or **DUB** mode by **clicking** or **ALT-clicking the encoder** when ECHO FREEZE is on. Audio will now be sampled into the loop when ever an external MIDI note is on, or the ECHO FREEZE button in pressed on the screen. Different patches can be selected to sample a wide range of sounds into the loop, and can include AUX input. To sample just AUX input, set the OSCGAIN parameter (POSTFILT / OSC page) to zero before sampling

* Sampling into the loop ignores the usual release time associated with any selected patch and applies an instant off

To exit loop construction click the main encoder. The loop continues to cycle while ECHO FREEZE is on. If ECHO FREEZE is turned off, the loop decays at the REPEATS rate

To toggle ECHO-FREEZE LOOP SEND to POST FILTER*, hold XPress and click the main encoder on the PATCH page

* ECHO FREEZE BUTTON shows "PF"

The following pages describe the button and pot functions available on each screen in detail, starting with the MAIN PATCH page and associated ALT pages, and then each of the PARAMETER EDIT PAGES in turn

PATCH

See P17 for [ALT] functions

RUN / STOP patch audio

shortcut [ALT] PARAM

led indicates active MIDI notes

T (top left) indicates env triggers are active

^ (top right) indicates oscEnv is active (see ENV page)

DRIFT slow continuous random drift of patch parameters. P1 enc = Drift depth if Drift is active (see page 11)

Set Drift mode, depth, and rate on ALT MORPH params page
Switch off DRIFT to stop further Drift changes, and retain the drifted sound. The acquired Drift offsets can be cleared (ALT+ DRIFT), temp stored (DRIFT+ Patch ▼), or recalled (DRIFT+ Param ▲), or saved-to or loaded-from the permanent Drift buffers 0-127 on the ALT MORPH params page (see p18). # under DRIFT indicates the drift buffer contains non-zero offsets
Drift can be automated using XfrzT (BENDS2 / XPLFO page)

MANUAL MORPH MODE(see page 11)
uses the main encoder to morph between the current patch, and a new target* patch

* select target while MANUAL is on, or hold MANUAL and touch Patch ▼ or Param ▲ buttons to decrement or increment the target

RAND randomize synth + drum params + kits, or randomize target when morphing
RAND Synth = [XPRESS] + tap PARAM
RAND Drums = [XPRESS +ALT] + PARAM

PATCH # 0 - 999

Tap the PATCH number on the screen or the metal ALT/Patch button to enable encoder patch select mode. If RUN is on, every encoder patch change is heard. To skip over patches hold ALT while turning the encoder

If any MIDI clk sync is enabled (MIDI page) shows "clk" in top R corner

For patch # decrement or increment, hold the patch number on the screen and tap the metal Patch ▼ or Param ▲ button

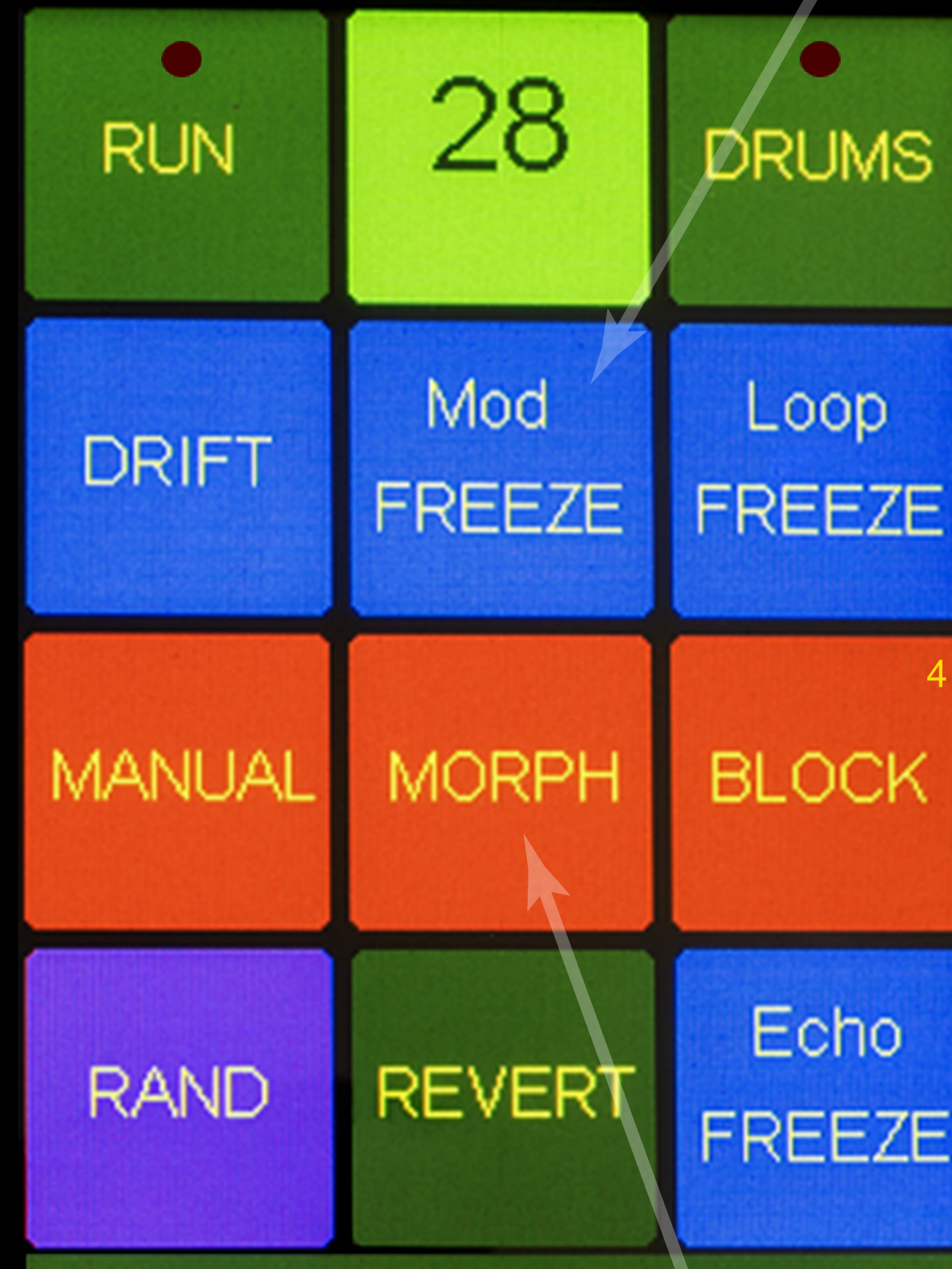

REVERT reload all patch parameters as last saved

SINGLE PATCH MORPH (see page 11)

auto-morphs from current patch to new target during RUN or MIDI notes. Activate MORPH, and use [ALT] encoder to select the target

STEP (top left) indicates STEP mode is on, resulting instant MORPH and BLOCK patch changes

MODFREEZE

freezes all modulation block waveforms
shortcut ALT + XPress* = freeze while down or reverse order XPress + ALT to freeze and include touch sensor effect

^ (top right) indicates oscEnv mode invokes mod Freeze

1-5 (top left) shows the current P1-3 encoder assignment GROUP

* ALT+XPress + encoder click toggles between Mod and Loop Hold

ENABLE / DISABLE Drums (MIDI and internal)
shortcut [ALT] + tap XPress (any page but Patch)

From STOP this shortcut activates RUN DRUMS

RED led indicates external MIDI drum output

BLUE led indicates internal drum output in addition to MIDI

YELLOW led indicates internal drums only

G (top right) indicates global drum parameters mode

LOOP FREEZE

freezes speech ROM data updates

shortcut ALT + XPress* = freeze while down

* ALT+XPress + encoder click toggles between Mod and Loop Hold

^ (top right) indicates current oscEnv mode invokes Loop Freeze

BLOCK MORPH (see page 11) continuous auto morphing between patches* in a block. Activating BLOCK sets the start of the block to the current patch. Relocate it using ALT+encoder. Set parameters on the ALT + MORPH params page

* Number in the top right corner shows the current block size

ECHO FREEZE (see page 15)

endless echo mode. Modify the loop using:
encoder short click for PUNCH mode
or ALT + click for DUB mode
ALT + long hold to clear loop

G (top right) indicates global echo parameters mode

[ALT] PATCH

Many of the buttons on the main Patch page have secondary functions when ALT (metal Patch button) is held down

[ALT] PATCH
stop all audio immediately
& turn off any note-on events

Hold ALT + click the main encoder to show SAVE* and DELETE options:

- SAVE save current parameters to Patch
- DEL delete current Patch
- SAVE Globals save all Global Parameters
- SAVE Template save current Parameters as Empty Patch "- -" Template**

[ALT] RUN stop all audio, preserve ENV & echo tails

[ALT] DRIFT clear the DRIFT offsets buffer to recover the undrifted sound

[ALT] RAND UNDO



[ALT] DRUMS toggle global drums
G (top right) indicates global drum parameters mode

[ALT] Morph
Show MORPH + DRIFT params page

[ALT] ECHO FREEZE MIDI setup*

* when ECHO FREEZE is inactive

[ALT] REVERT show Multi-Mod / Keybd page

* Save is only allowed to the current patch, or an empty slot. To overwrite another existing patch, first delete it

** The Template parameters are loaded when an empty slot is encountered on Patch changes, except when morphing which instead loads random parameters into the target patch

DRIFT MORPH

Access via PATCH page
[ALT] + MORPH

DRIFT MODE Drift Synth params,
Drums, or Both

(GRADUAL) MORPH TIME
time to auto morph from source to
target patches when STEP MODE is off

STEP RATE*
used instead of MORPH TIME
when STEP MODE is enabled
* can be XP mapped and P1-3 assigned

DRIFT BUFFER SELECT (0-127)
indicates that the Drift Buffer exists, and
@ that it is currently loaded
click Encoder = LOAD Buffer
ALT+ click = SAVE to Buffer (tap screen)
XPress+ ALT+ click = DELETE Buffer
SAVE stores the current drift offsets to
the selected permanent Drift Buffer,
unless offsets are zero

* All DRIFT and MORPH parameters are global rather than patch specific. To retain their current values as power-up defaults, use SAVE GLOBALS from the main Patch page (see also page 11)

DRIFT DEPTH* (see also page 11)
Sets the extent to which parameters are
randomly drifted. Wind back to 0 at any
time to drift back to original values
* can be XP mapped and P1-3 assigned

BLOCK MORPH WAIT TIME
time to hold morphing parameters constant until
next morph interval in non-STEP block morphing

DRIFT RATE* Sets the rate at which parameters
Drift. Faster rates cause larger effects
* can be XP mapped and P1-3 assigned

BLOCK SIZE FOR BLOCK MORPHING
* set to 0 for continual random target patches that morph back
to the source patch during each morph time interval

The GND1 allows gradual or STEP morphing
between patches

STEP MODE switches parameters instantly at
STEP RATE , or MIDI note-on (if no other notes active)
OFF, ON, ONsync (restarts loops),
KeyStp (STEP activated by MIDI note on)
KeySnc (MIDI note STEP + restart loop)

MANUAL MORPH EXPRESSION
assign an external controller for manual
morphing (modwheel, velocity, breath control,
aftertouch) "-" indicates the selected controller
will be disabled from simultaneously affecting
the expression matrix

STEP MODE SWING
alternating patch hold time asymmetry
between consecutive patch changes in
step mode 64 = 50/50 (no swing)



BLOCK MORPH ORDER
sets the order and mode in which
patches in the block are morphed*:
Sequential, Random, Seq *without drum
morphing*, Rand *without drum morphing*

* Whenever the GND-1T morphs to a blank patch it temporarily
creates a new random target. A block containing only blank
patches will morph between continually randomized targets

MULTI-MOD SCENE KEY RETRIG

Access via PATCH page
ALT+MultiMd Keybd

NULL ALL MULTI-MODS

APPLY ALL MULTI-MODS
updates all mod parameters to
include the effect of the
MULTI-MODS and then nulls
the MULTI-MODS

SCENE* SELECT (0-127)
indicates that the Scene exists, and
@ that it was the most recent one applied
click Encoder = LOAD SCENE
ALT+ click = SAVE to Scene (tap screen)
XPress+ ALT+ click = DELETE Scene

POST FILTER CUTOFF KEY TRACKING
Cut-off follows MIDI Note-On values

KEY-DOWN ENV RETRIGGER on additional* Note-On
events, starting from either current ENV value, or zero
* First active note always triggers ENV

The MULTI-MOD parameters simultaneously apply a bipolar offset to the Depth, Mix, W1 or W2 values in many of the modulation blocks in the GND-1T, or to the LFO rates (LFO1,2,SLFO,CLFO). They are saved along with the other Patch parameters, are fully reversible on Patch recall, and can be inhibited by parameter excludes

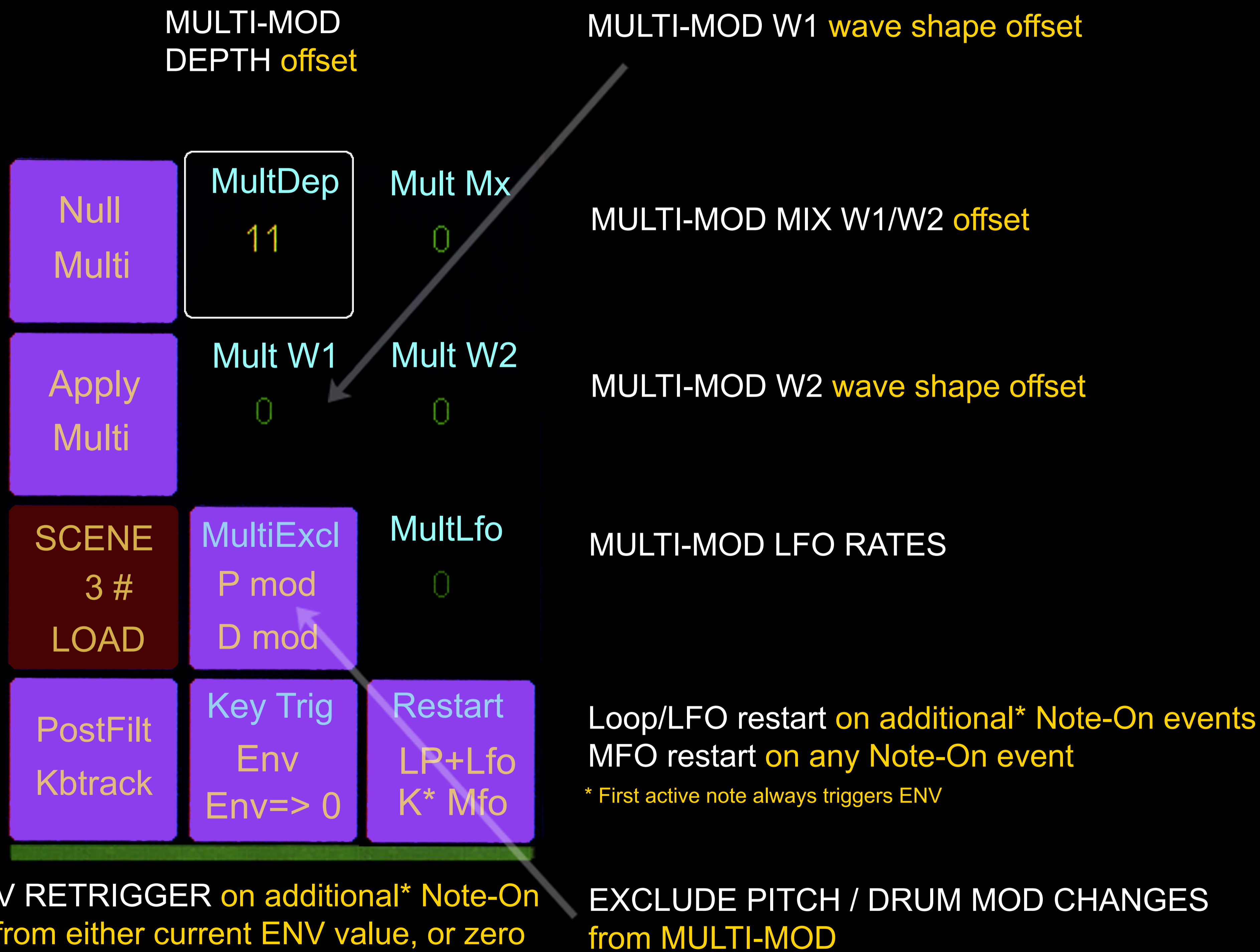

* SCENE SAVE stores the current parameters (including drum on/off status) as you hear them, and their morph excludes, without overwriting the saved Patch shown on the main Patch page. On Scene load, parameters will therefore usually differ from those of the patch # shown on the Patch page. **WARNING: saving the preset after SCENE load will irreversibly overwrite the original Patch parameters.** SCENES also store the current global morphing parameters, BLOCK morphing on/off status, block start patch, individual drum mutes if active, and touch sensor attack / release times. SCENES can therefore also be used as presets for these global parameters, and the Scene's morph excludes, both of which are retained upon subsequent Patch loads

MIDI SET UP

Access via PATCH page
ALT+MIDI

GND-1T MIDI Rx CHANNEL
use the main encoder to set the MIDI receive channel (auto saved)
[ALT] MIDI CHANNEL tap toggles MIDI SysEx receive enable

MIDI THRU CONNECTIVITY
Thru Off, USB->DIN, DIN>USB, DIN -> DIN, DIN->DIN+USB, USB<->DIN, HOST->DIN, HOST->USB, HOST->DIN+USB (auto saved)

[ALT] SysEx SEND 1
send last saved version of current patch (& load it)
[ALT + XPress] SysEx SEND C
send currently active patch parameters

[ALT] SysEx SEND ALL
send all saved patches in the GND-1T

MIDI CLOCK SYNC / PPQN SCALING ENABLES*
for Tempo, LFO1+2, Loop length, and Drum rate

* when any of these are enabled, the PATCH number button on the main Patch page shows "clk" in the top right corner



MIDI CLOCK PPQN SCALERS
24 = unity scaler at 120bpm
12 = double rate at 120bpm
(0 = 48x rate at 120bpm)
48=half rate at 120bpm
etc

Hold [ALT] after selecting one of the PPQN scalers to simultaneously change all 4 scalers with the main encoder

INDEX

Most of the GND-1T patch parameters are available via 12 Parameter edit pages that are selectable from the index screen. From any page hold down the metal Param button to show the index page. From any edit page, tap Param to toggle between edit and index pages

On the index page, select the desired Parameter page by pressing its button on the screen, or rotate the encoder and click it



[ALT] Drum2 goes directly to the MIDI DRUM MAP page rather than DRUM2 / WORD

This enables quick access to e.g. individual drum note mutes from any page by holding down Param and tapping Drum2 once the index page shows

To return to the Patch page from any page, briefly tap the metal Patch button

PITCH

The speech chip uses ROM based, time-varying pitch contours for each word/loop. These are scaled up or down by the GND-1T PITCH parameter. Set to values around 80 for the original speech chip pitch

PITCH

Main encoder steps in semitones
Finer resolution is available using
P1-P3 assignment (P2 factory default)

PITCHMOD mode
set polarity and uni- or bipolar
modulation

PITCH MOD W1 waveform select
W1 waveforms are derived from
LFO1, ENV, SLFO1, CLFO1, LOOP,
OscEnv, and Drum-note signals

TUNE pitch fine tuning parameter
(+/- 1 semitone range, 64=0)

PORTAMENTO sets the time taken
to go from one note pitch to the next
when two or more notes are active



PITCH MOD MIX
mixes W1 and W2 pitch modulators.
0=W1, 127=W2, 64 = 50/50

PITCH MOD DEPTH

PITCH MOD W2 waveform select
W2 waveforms are derived from
LFO2, ENV, SLFO2, CLFO2, LOOP,
OscEnv, and Drum-note signals

FIFTHS adds a second oscillator waveform
a fifth below or above the original pitch.
“md” indicates modulated fifths, which varies
between off, and a fifth below or above
according to the Pmix waveform value

PITCH BEND DOWN RANGE

Sets max pitch bend down in semitones

* Note this is a global parameter affecting all patches.
Save using SAVE GLOBALS on the main patch page

PITCH BEND UP RANGE

Sets max pitch bend up in
semitones

* Note this is a global parameter affecting
all patches. Save using SAVE GLOBALS
on the main Patch page

STEADY PITCH

Replaces the time-varying pitch contour
defined for each word in the speech ROM
with a steady pitch

DRUM1

There are no preset drum patterns stored in the GND-1T. All drum events are created on-the-fly by a unique algorithm that responds to the DRUM TRIGGER source signals and the drum parameter settings

INTERNAL DRUM TRIGGER SRC
Selects whether speech chip ROM signals or LFO1/2 are used as the "DSRC=0 signal"

DRUM TRIGGER SENSITIVITY
scales DRUM TRIGGER SOURCE signals, generally causing more triggers at higher settings
set to 0 to inhibit triggers

DRUM TRIGGER RATE
sets upper rate limit of trigger events
set to 0 to inhibit triggers

DRUM PATTERN
modifies event timing in the drum algorithms, resulting in pattern variations

DRUM TRIGGER SOURCE

for the input to the drum algorithm. Sets the balance between internal signals (either speech ROM or LFO) at 0, and audio signals (PF output*, echo, USB) at 127. The internal signals often produce slower and more regular triggers

* For "Run Drums only" mode, the PF input rather than output is used by D src, as the output is muted by the ENV



DRUM TRIGGER SENSITIVITY MOD
uses DTmix as modulator (additive)

QUANTIZE MODES off, DRmod only, improv only, or both

DRUM TRIG SENS MOD MIX
mixes W1 and W2 drum modulator waveforms selected on DRUM2 edit page
Also used for D kit modulation (DRUM2 page)

DRUM RATE+PATTERN MOD MIX
mixes W1 and W2 drum modulator waveforms selected on DRUM2 edit page

IMPROVISE
depth of additional improvisation / randomization applied to the drum triggers

DRUM PATTERN MOD depth uses DRPmix as modulator

DRUM TRIGGER RATE MOD depth uses DRPmix as modulator
Shows "+" at low D rates for which modulation becomes additive (added to D rate) rather than multiplicative (scales D rate)

DRUM2 / WORD

Hold ALT to show "MIDI KITS" button in the top left corner of this page, and press it to show the MIDI DRUM MAP page

DRUM KIT MOD DEPTH
scales DTMIX waveform to switch from main kit -> m1 -> m2 as modulation increases.

For external MIDI drums, the current MIDI drum map is the main map, and the next two act as m1 and m2 with wrap around to map 0 after 2

ALT+ kit mod = MIDI KITS button
(shows MIDI DRUM MAP page)

MAIN INTERNAL DRUM KIT SELECT*
active at zero or low kit-mod levels. If off, internal kits m1 and m2 are also disabled. LED shows current active kit

* see MIDI reference for kit list

DRUM DECAY
Used to shorten the sounds of the internal drum kits. Set to 127 to leave original sample lengths

DRUM OVERDRIVE * new to FW 241103
Tube overdrive for internal drums

RANDOM WORD (+ WORDBANK)
Other parameter settings may make words unintelligible. Use INIT to clear those
ALT+ RAND WORD = GLITCH* WORD randomizes both WORD / WORDBANK and GLITCH parameter value

* adjust glitched word loop length on LOOP page

DRUM MOD W1 waveform select
W1 waveforms are derived from LFO1, ENV, SLFO1, CLFO1, LOOP, OscEnv, and Drum-note signals

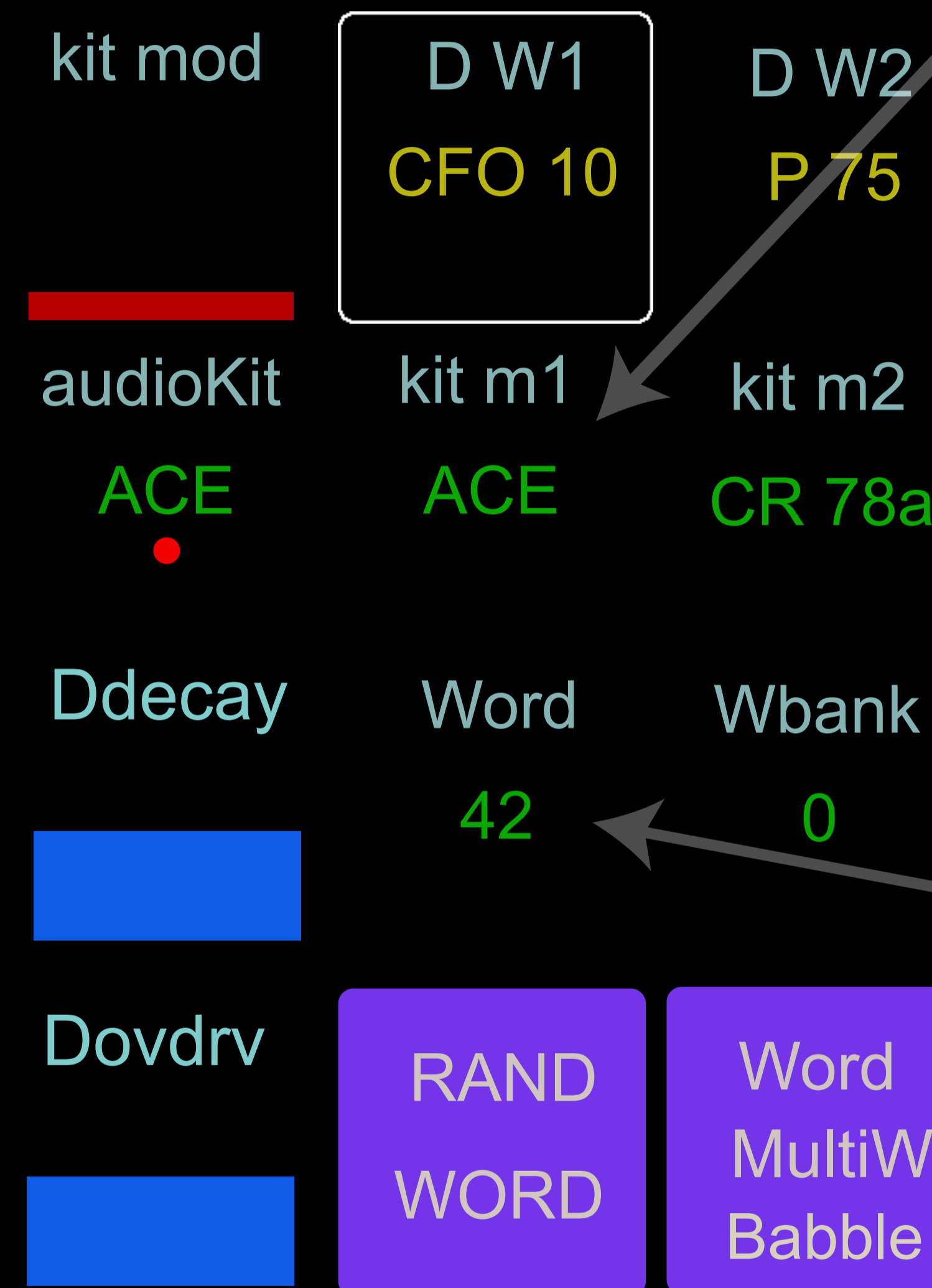

ALT + SPEAK MODES = INITIALIZE PATCH nulls all bends, modulators, and expression matrix* to allow intelligible speech sounds.

* except Breath control XP (touch sensor by default) for Pitch is set to -31

INTERNAL DRUM KIT MOD-1 select
active at medium kit mod levels
set to Off for no drums at those levels

DRUM MOD W2 waveform select
W2 waveforms are derived from LFO2, ENV, SLFO2, CLFO2, LOOP, OscEnv, and Drum-note signals

INTERNAL DRUM KIT MOD-2 select
active at high kit mod levels
set to Off for no drums at those levels

WORD BANK SELECT
Choose one of 5 banks each with 60 words

WORD SELECT IN CURRENT WORDBANK
Word 0 - 59

SPEAK MODES
allows the speech chip to produce intelligible speech sounds if bends and modifiers are zero. If no speak mode is selected, sounds are more random

Word* = Single word, MIDI notes change Pitch
MultiWord = different word on each MIDI key
5 wordbank key-layouts, with 60 words each
Babble = new random word for each loop
MIDI notes change pitch

* Set Loop length to 127 for one shot speech WORDS (non looping) when Glitch and Gravity are also set to 0

MIDI DRUM MAPS

+ DRUM OUTPUT and INDIVIDUAL DRUM MUTES
FOR MIDI + AUDIO KITS

SAVE MIDI DRUM MAPS*

Saves current MIDI drum notes for
all three maps as power up default

*not saved by SAVE GLOBALS

ACTIVE MIDI DRUM MAP

Set to 0,1 or 2. The DRUM KIT MOD
DEPTH parameter (DRUM2 page)
modulates this map up to the next two
maps, wrapping around to 0 after 2.

e.g. with the current MIDI MAP set to 2, moderate
modulation levels cause the map to switch to 0, and
strong modulation levels to MAP 1

DRUM OUTPUT SELECT

Select whether to send drum triggers
to external MIDI devices, use
them to play the internal Drum Kits
of the GND-1T, or both. Internal kits
are selected on the DRUM2 page

ENABLE INDIVIDUAL DRUM MUTES

Activate individual drum note mutes, and allow setting or clearing
of mutes by tapping on any drum note pot. When MUTES is switched off,
toggle individual (inactive) drum mutes using [ALT] tap. Mutes apply
to both MIDI and internal drum kits and are cleared on power up

Access via DRUM2 page [ALT] kit mod button or:

SHORTCUT from any page hold metal Param button until
index page appears, keep PARAM down, tap Drum2/WORD

SAVE MIDI	Kick 36	Snare 38
D MAP 0	O hat 42	C hat 46
D out MIDI internal	L Tom 45	H Tom 50
MUTES	Clap 39	Rim 37

MIDI DRUM MAPPING

MIDI Drum Maps (D MAP) 0,1 and 2 define
for each map the 8 note values sent out by
the GND-1T as external MIDI drum triggers.
Select the current MIDI drum map, click on
any of the 8 drum buttons and use the main
encoder to set the midi note value sent out
for that drum trigger. The maps are Global
parameters. To save them for subsequent
sessions, click the SAVE button on this page

MFO

The MFO (mid freq osc) spans subsonic to moderate audio rates. In addition to its use for amplitude modulation and ring-modulation, it can be used to modulate pitch and speech filters, producing unique effects and timbres

OSCILLATOR SYNC
synchronizes MFO rate to oscillator frequency

AM TURBO enables stronger AM waveshaping

AMPLITUDE MFO DEPTH
modulates synth amplitude with MFO signal

MFO MOD
Uses the MFO MODMIX signal to modulate the MFO modulator. Alters MFO mod-depth, MFO rate, or both, according to MFO MOD MODE

MFO RATE



MFO MODMIX
uses the two waveforms selected in the Loop modulation block

OFFSET

offsets the MFO modulator so it can produce bipolar modulation. Set to max for ring-modulation and 0 for unipolar AM modulation

MFO FINE TUNE for accurate control of (sub)harmonic modulation interaction with OSC frequencies

MFO WAVESHAP select one of 16 possible MFO waveshapes (see the MIDI reference for a list). Select SIN for traditional ring-modulation and lowest number of sidebands

FILTER MFO DEPTH
modulates speech filters with the MFO signal

MFO MOD MODE
selects whether modulation of the MFO applies to mod-depth, rate, or both

PITCH MFO DEPTH
modulates OSC pitch with the MFO signal

BEND1

GLITCH

This parameter is the equivalent of having a large number of "bend switches" in classic hardware circuit bending. Use in conjunction with the INIT and RANDOM WORD commands on the DRUM2 / WORD page to hear the familiar "nonsense" speech sounds

FLIP flips the speech ROM data

SOFT BENDS changes Gravity and Plasma response curves to produce a milder effect.

INVERT PLASMA inverts the effect of Plasma to produce sparser rather than denser sounds.

NULL ALL BENDS

GRAVITY and PLASMA are highly non-linear and at higher levels in particular can lead to loud and highly resonant sounds. Use Soft B, iPlasma, and the Filter 'Derez' parameter to moderate their effect

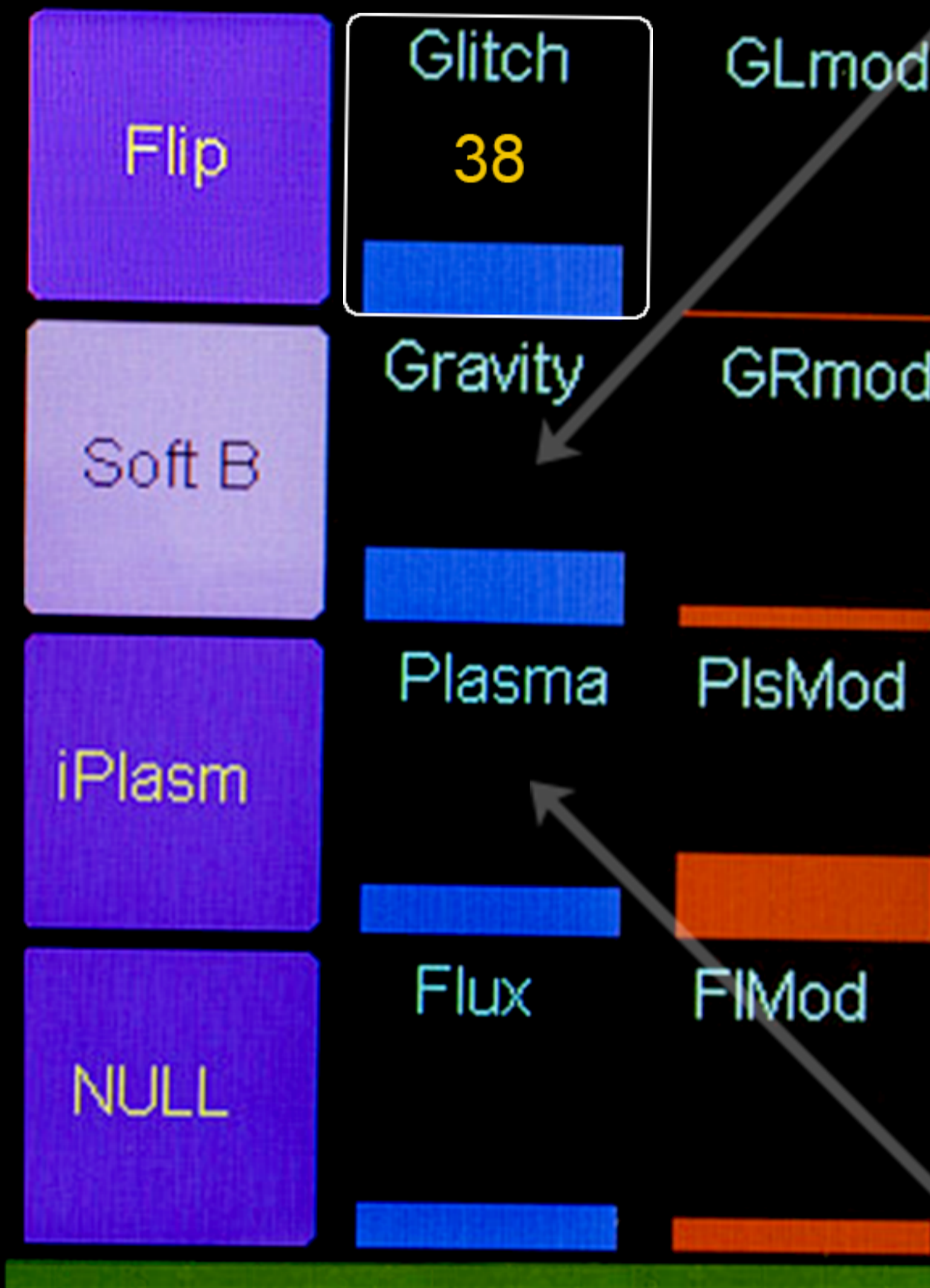

GRAVITY

binds data from the speech ROM to provide denser sound

GLITCH MOD DEPTH

GRAVITY MOD DEPTH

PLASMA MOD DEPTH

FLUX MOD DEPTH

Bendmix mod waveform for these 4 modulators is set on the BEND2 page

FLUX

A milder circuit bend that often produces more subtle rhythmic variations

PLASMA

Modifies how gravity is applied. Use INVERT PLASMA to invert its effect and obtain sparser sound

BEND2 XPIfo

BLUR

blurs PITCH, FILTER and level of voiced speech ROM fragments

BENDS MOD W1 waveform select W1 waveforms are derived from LFO1, ENV, SLFO1, CLFO1, LOOP, OscEnv, and Drum-note signals

EXPRESSION FREEZE MODE sets LOOP, modulation*, or Echo FREEZE, or DRIFT to be auto-activated when XFrz T is exceeded by the sum of its expression matrix signals **

* For Modulation XP freeze, the XPIfo signal is not included in the sum to avoid Freeze lock-up

XPLFO MOD W1 waveform select W1 waveforms are derived from LFO1, ENV, SLFO1, CLFO1, LOOP, OscEnv, and Drum-note signals

The XPLFO modulator is used as an automated expression controller signal that can be applied to any continuous parameter via the expression matrix. To assign a parameter in the expression matrix hold the parameter on the screen and touch the XPRESS sensor

WARP

Unique audio band self-modulation that causes frequency warping and distortion. Adopted from a custom bend developed initially on hardware Speak & Spell speech chips

BENDS MOD MIX

mixes W1 and W2 bend modulators. 0=W1, 127=W2, 64 = 50/50

ERODE (new to FW 241103) corrupts individual bits in the ROM data stream to produce variations on the current patch theme. Rate covaries with the Tempo parameter

BENDS MOD W2 waveform select W2 waveforms are derived from LFO2, ENV, SLFO2, CLFO2, LOOP, OscEnv, and Drum-note signals

XPLFO SCALER

Scales down the magnitude of the XPLFO waveform before being applied in the expression matrix

XPLFO MOD W2 waveform select W2 waveforms are derived from LFO2, ENV, SLFO2, CLFO2, LOOP, OscEnv, and Drum-note signals

EXPRESSION FREEZE THRESHOLD

Sets threshold that the sum of the expression matrix signals for this parameter must exceed to trigger a Loop, mod, or echo-Freeze, or Drift command (led turns on)

** The expression matrix values for XFrz T scale their controller signals prior to testing against Xfrz T. Set the matrix value to 127 to compare a controller value directly against the threshold

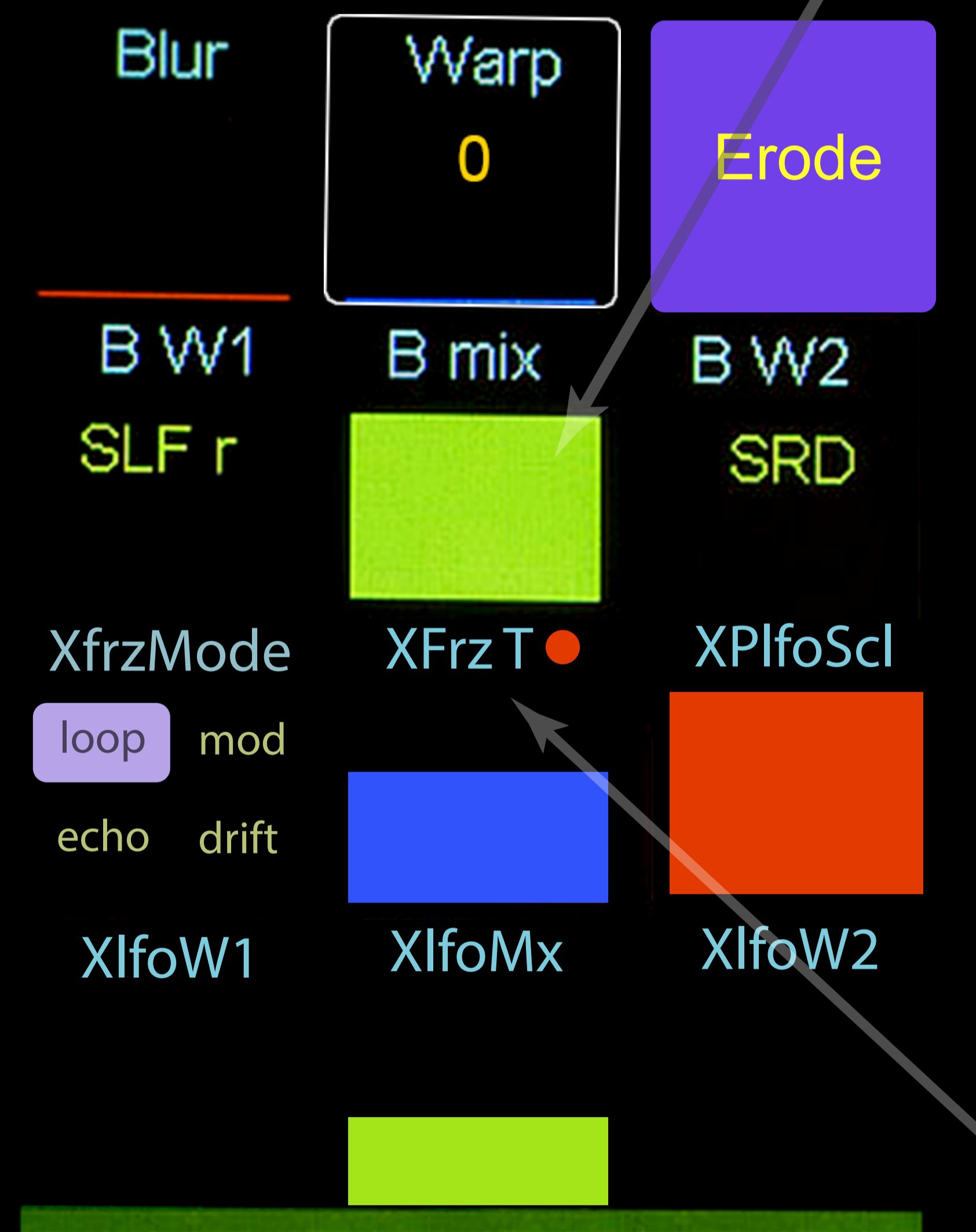

XPLFO MIX

mixes XPLFO W1 and W2 waveforms to produce the XPLFO signal for use in the expression matrix 0=W1, 127=W2, 64 = 50/50

LOOP STEREO

RAND LOOP

randomizes loop ROM address and turns off speak modes
[ALT] Restore LOOP restores ROM address and speak mode state*

LOOP MOD W1 waveform select
W1 waveforms are derived from LFO1, ENV, SLFO1, CLFO1, LOOP, OscEnv, and Drum-note signals

BENDS STEREO MOD DEPTH
uses BENDS MOD MIX waveform to modulate BENDS STEREO

PHASE STEREO

Imparts a (milder) stereo image using phase differences

* Loop restore values are (re)defined by these events:
Patch load, save, or revert
RAND synth and WORD functions
Setting Word or Wbank (Drum2 page)
(new in FW241211)

LOOP LENGTH*

sets the number of speech/sound elements to include in the loop. Setting this very short allows the loop to be used as a complex oscillator waveform, which can be useful e.g. for 'keyboard patches'

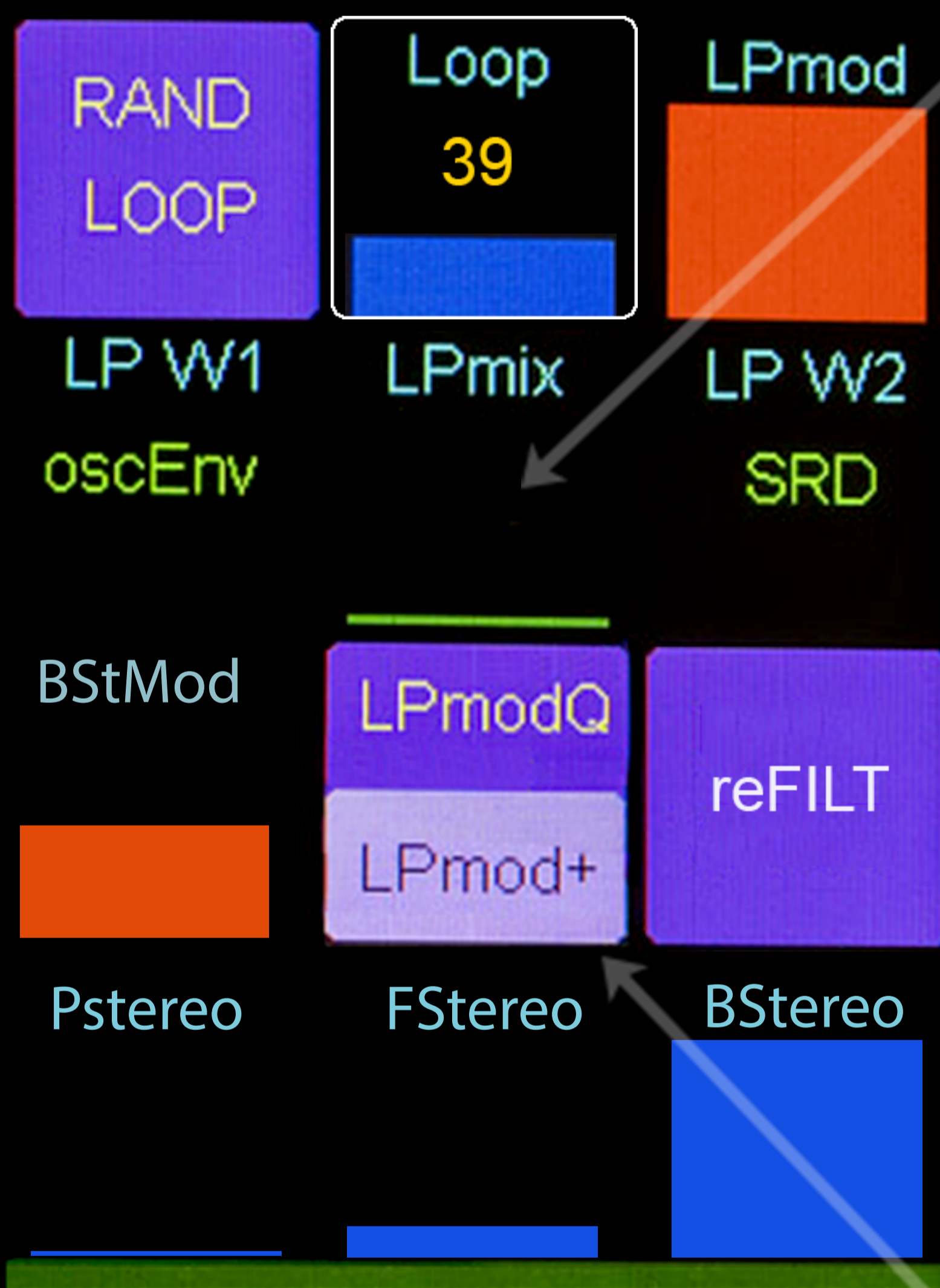

FILTER STEREO

Introduces asymmetric offsets between L and R speech filters, producing essentially different speech formants

* Set Loop length to 127 for one shot speech WORDS (non looping) when Glitch and Gravity bends are also set to 0

LOOP LENGTH MOD MIX

mixes W1 and W2 loop modulators. 0=W1, 127=W2, 64 = 50/50

LOOP LENGTH MOD DEPTH

LOOP MOD W2 waveform select
W2 waveforms are derived from LFO2, ENV, SLFO2, CLFO2, LOOP, OscEnv, and Drum-note signals

LOOP ReFILTER mode

reloads the FILTER and resets the effect of GRAVITY on each loop cycle to produce more regular loops

BENDS STEREO

Activates dual circuit bending engines for potentially strong stereo* streams with independent but temporally related sounds in L and R channels

* requires bend parameters to be active

LOOP MODULATION MODE

LPmod+ sets additive LOOP length modulation, otherwise modulation is multiplicative (scaler). LPmodQ* quantizes modulation and restricts it to integer (sub)multiples of the loop length

* not available in additive mode

LFO / TEMPO

LFO MOD DEPTH

uses the BENDS mod mix waveform to modulate LFO1 and LFO2 rates

PULSAR LFO1/2 MODE

LFO 1 and 2 take turns in completing one oscillation cycle, and are held at 0 during their inactive cycle

FREE RUNNING LFOS

LFOS are not restarted on RUN or MIDI Note-on events

TEMPO

sets the rate at which speech data are updated from SPEECH ROM i.e. how fast words are spoken, or more generally the speed of the sounds in a loop. For very short loops with only a single data fragment, Tempo changes will not be audible because the same parameters are reloaded at each update

LFO1 RATE
led shows rate



TEMPO MOD DEPTH
uses the Loop length mod mix waveform to modulate Tempo

LFO1 LOOP SYNC

when active, LFO1 rate is a scaled version of the estimated (variable) Loop rate. Rate limited for very short loops. Only effective if LPmod+ is off (LOOP page)

LFO2 RATE led shows rate

LFO2 LOOP SYNC

when active, LFO2 rate is a scaled version of the estimated (variable) Loop rate. Rate limited for very short loops. Only effective if LPmod+ is off (LOOP page)

CLFO1 (left led) and CLFO2 (right) RATE sets the rate of a "3D" Chaotic LFO where CLFO1 and 2 are projections of that oscillator in two of the dimensions. Their rates have time-varying ratios, and their varying amplitudes rarely reach extreme values of 0 or 1

CROSS MODULATION DEPTH

LFO1, LFO2, and SLFO three-way cross modulation depth

SLFO 1 (left led) and 2 (right) RATE sets the rate of the (Slow) SLFOs. SLFO2 rate is a fixed non-integer multiple of SLFO1 (about 1.44x)

ENV

Full AHDSR ENV triggers are activated by MIDI Note-On events. And also by LFOs, SLFO1, CLFO1, LOOP-start and RUN activation if the corresponding trigger enable at the bottom of this screen is on

If RUN is started without any active trigger source, a modified ENV is generated that applies ATTACK time on RUN, and remains at maximum until STOP is issued and RELEASE time is applied

ATTACK TIME
applies to all ENV / OSCENV events
Optionally modulated by ADmd
(Attack/Decay modulator)

SUSTAIN LEVEL
applies to triggered AHDSR events only

RUN ENV TRIGGER ENABLE
when off (default) RUN / STOP applies only Attack / Release times according to the Amp Env depth. When on, starting RUN triggers a full AHDSR event

LFO 1 and 2 ENV TRIGGER ENABLES

Although AHDSR and osc OSCENV envelopes share ATTACK, HOLD, and RELEASE parameters they operate independently with AHD triggers always at TEMPO rate regardless of any AHDSR triggers

HOLD TIME
applies to AHDSR and OSCENV events only

RELEASE TIME
applies to all ENV events
Optionally modulated by ADmd

DECAY TIME
applies to AHDSR and OSC ENV events only. Optionally modulated by ADmd

ATTACK / DECAY MOD DEPTH (ADmd)
uses Pitch mod waveform to shorten attack and decay times as pitch mod rises

OSC ENV MODE
When off, OSC levels are updated immediately from the speech ROM and scaled only by OSCGAIN (OSC page). Switch to various AHD modes to enable attack/hold/decay smoothing*. See page 12 for more details

* RUN button shows "Λ"

LOOP SYNC ENV TRIGGER ENABLE

SYNTH AMPLITUDE ENV MOD DEPTH
sets depth of ENV amplitude modulation



SLFO and CLFO ENV TRIGGER ENABLES

FILTER

The speech chip uses specific sequences of multi-resonance speech filter settings to create each word. The GND-1T FILTER parameter shifts/warps those filter frequencies and resonances

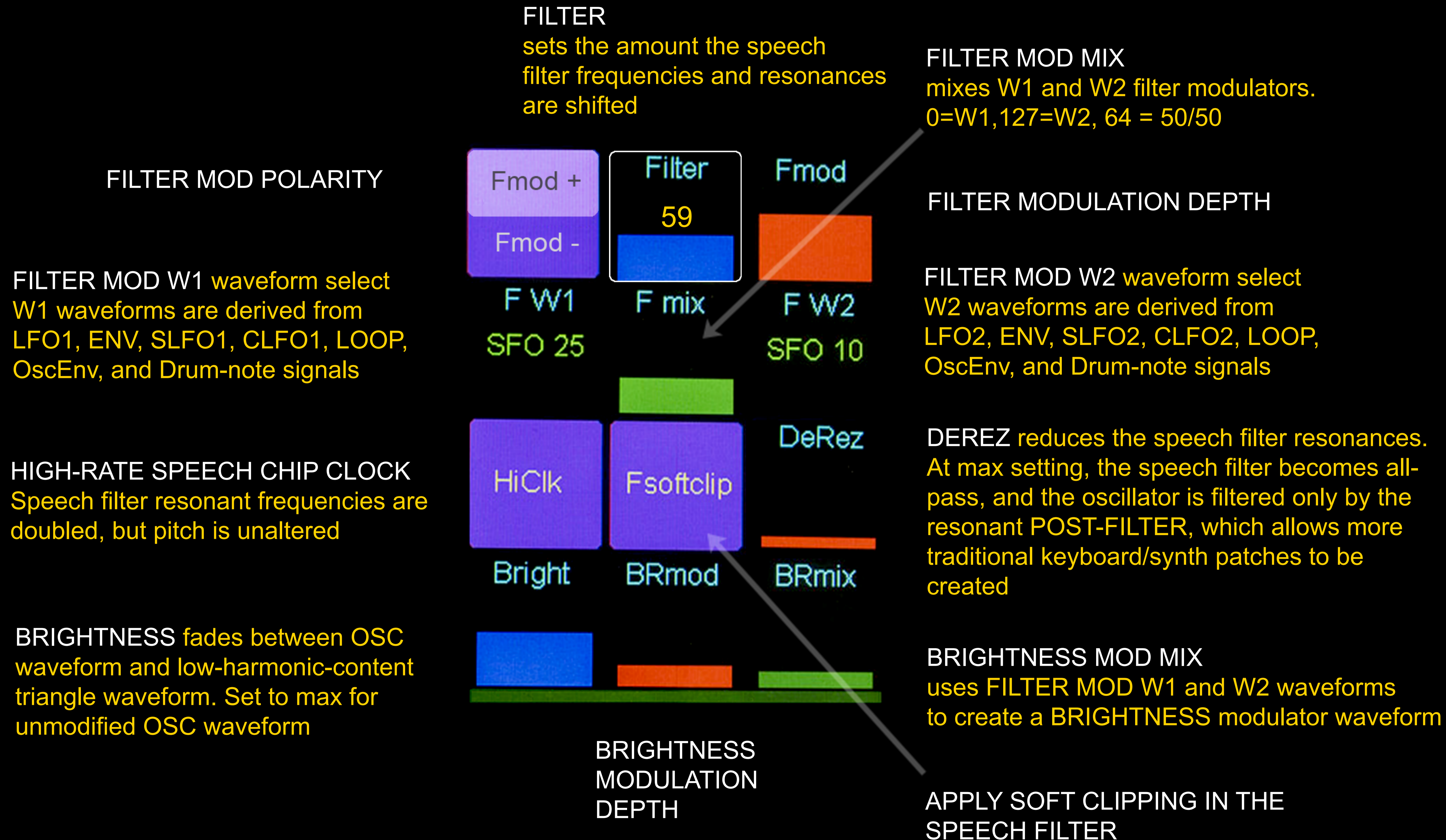

POSTFILT OSC

The POST-FILTER follows after the speech FILTER output is summed with the AUX input, and OverDrive is optionally applied. USB audio and Drums can also be added to the POST-FILTER input (MIX page), as can echo-loops when ECHOFREEZE is on (see page 15)

POST-FILTER BIPOLAR MOD modulates Pitch both up and down, and extends the total range

POST-FILTER MOD W1 select W1 waveforms are derived from LFO1, ENV, SLFO1, CLFO1, LOOP, OscEnv, and Drum-note signals

POST-FILTER TYPE select low pass filter type from mild HF cut, analog modelled resonant Ladder, or low pass State Variable Filter

OSC WAVEFORM SELECT with 16 steps cross fading between consecutive waveforms: VOX, SAW, SQR, Pulsed Noise (PNZ), PWM, and octave-up SQR

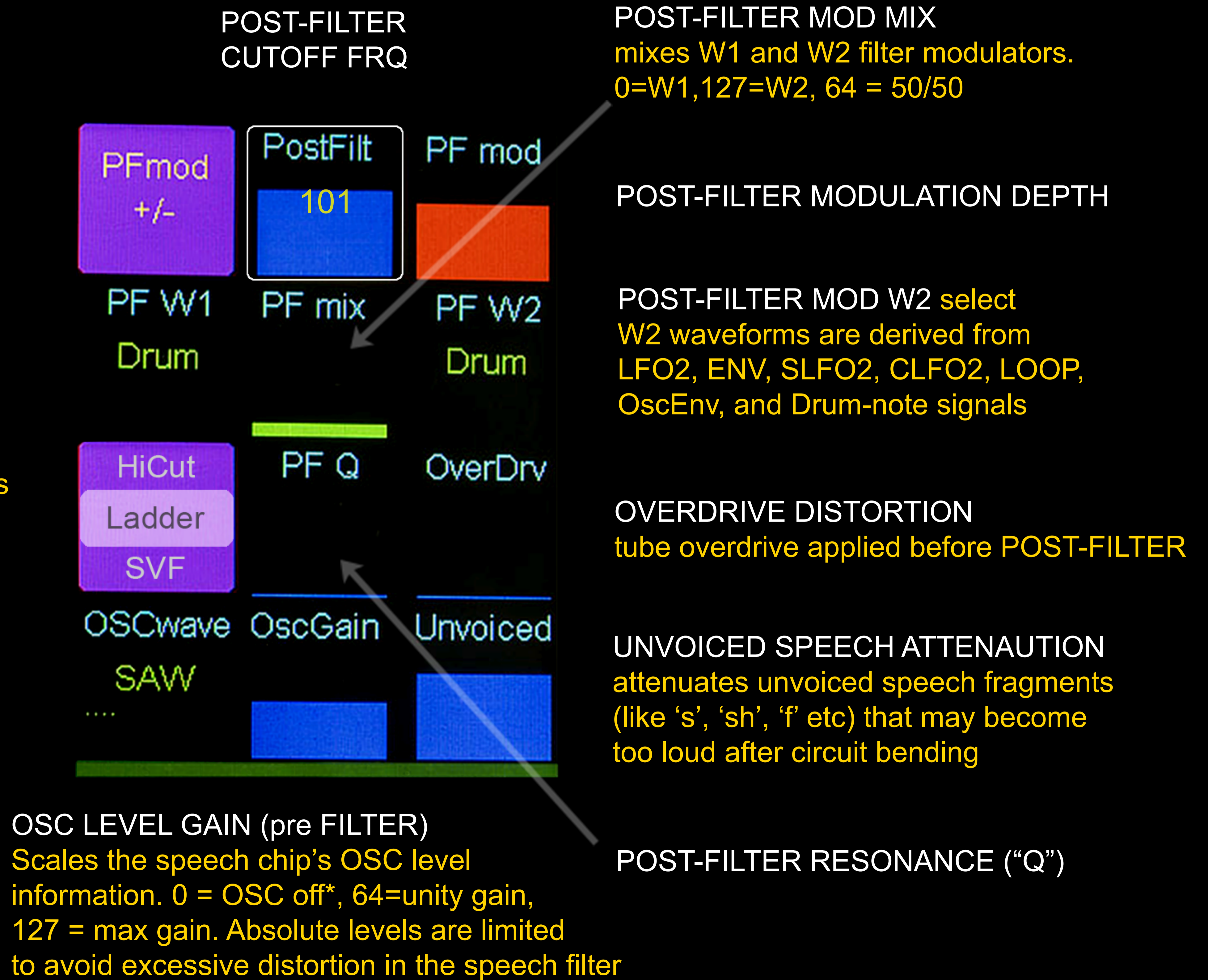

* Set to 0 allow AUX input signals to be heard without Synth sounds

MIX ECHO

POST-FILTER OUT VOLUME for analog and USB audio out. **Synth + AUX in are always routed through the PF.** Optional additional inputs include drums, USB audio in, and echoFreeze Loop

DRUM VOLUME for external MIDI out, and internal drums prior to D->PF mix. Affects both analog and USB audio out

ECHO VOLUME for analog and USB* audio out
(ALT+POSTFILTER ENC)

* when mix>usb is selected

ECHO INPUT SELECT
Select any combination of Post-Filter, Drums and USB audio

USB AUDIO INPUT LEVEL

* Global parameter affecting all patches. Save using SAVE GLOBALS on the main Patch page

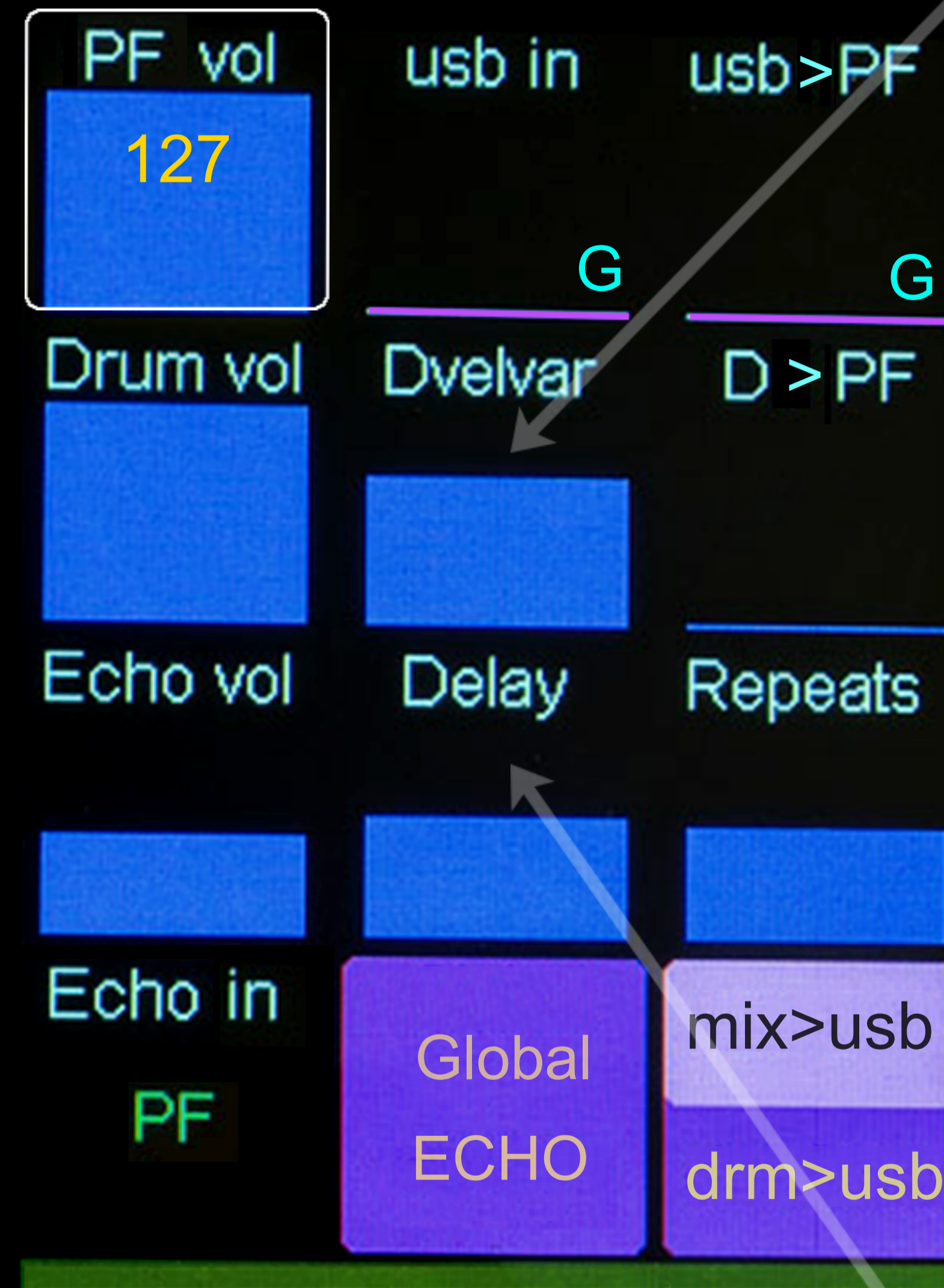

DRUM OUTPUT VELOCITY VARIATION sets amount of 'Note-On velocity variation' applied to the drum trigger signals

USB AUDIO INPUT POST-FILTER MIX sets proportion of USB audio input signal sent to POST-FILTER

* Global parameter affecting all patches. Save using SAVE GLOBALS on the main Patch page

DRUMS POST-FILTER MIX sets proportion of internal DRUMS audio sent to POST-FILTER

ECHO REPEATS
Echo feedback amount

* ignored if echo Freeze is active (see Patch page)

USB AUDIO OUTPUT SELECT
select off, entire mix, or (dry) internal drums only, to be sent to USB audio output. If **drm>usb** is selected unfiltered Drums are excluded from the analog audio output (but PF drums are retained)

ECHO DELAY TIME
(up to about 2.5 sec)

GLOBAL ECHO
allows current echo parameters to be retained across Patches

* Note that saving a patch with inherited global echo parameters will overwrite the patch's own parameters

XPMAP

XPRESS + hold main encoder (from any page)

The expression matrix in the GND-1T allows any continuous patch parameter to be modulated by controllers modwheel, velocity, breath-control, after-touch, and the automated XPIfo. To link a parameter to the matrix, hold its pot in the Param Edit pages and touch the metal XPRESS button to show this page. Touch any controller pot to set the strength of its effect on the parameter being mapped (-127 to +127).

All five XP values for every patch parameter in the GND-1T are saved and recalled with the patch.

Three controls at the bottom of the XPMAP page set touch sensor, note on, and main encoder assignments

Parameter being expression mapped and its MIDI CC info for external XP mapping

Effect of Breath controller on the parameter being mapped

Clear current parameter XP values
+ALT = CLEAR ENTIRE MATRIX !

TCH XP* maps the metal XPress touch sensor to Modwheel, Breath-control, or Aftertouch controllers, which allows the touch-sensor to affect all parameters mapped to that controller in the expression matrix.

Alternatively, TCH XP can be mapped to pitch-bend up or down, ENV trigger (optional + Breath), or Note trigger (optional + Breath)

Effect of Modwheel on the parameter being mapped

Effect of After-touch on the parameter being mapped

Effect of MIDI Velocity on the parameter being mapped

Effect of XPIfo on the parameter being mapped

Touch Sensor Release Time*

Slows the decay of the touch sensor value after touch release. Can be XP mapped and P1-3 assigned

ENC XP* maps main encoder to modW, Breath-control, or After-touch. This allows the encoder** to control all parameters mapped to that controller in the expression matrix

** when the PATCH page is on display

Touch Sensor Attack Time*

Slows the rise of the touch sensor value upon touch. Can be XP mapped and P1-3 assigned

* Global parameters, save using SAVE GLOBALS on Patch Page

NOTE XP* maps MIDI note-on events to expression controller values for modW, Breath-control, or After-touch. Or maps each note to a different Patch*** (with or without pitch options). Select the patch for middle C using the main encoder in the usual way. Holding a note down at the same time shows the patch for that note and preserves drift buffer offsets

*** new to FW 241211

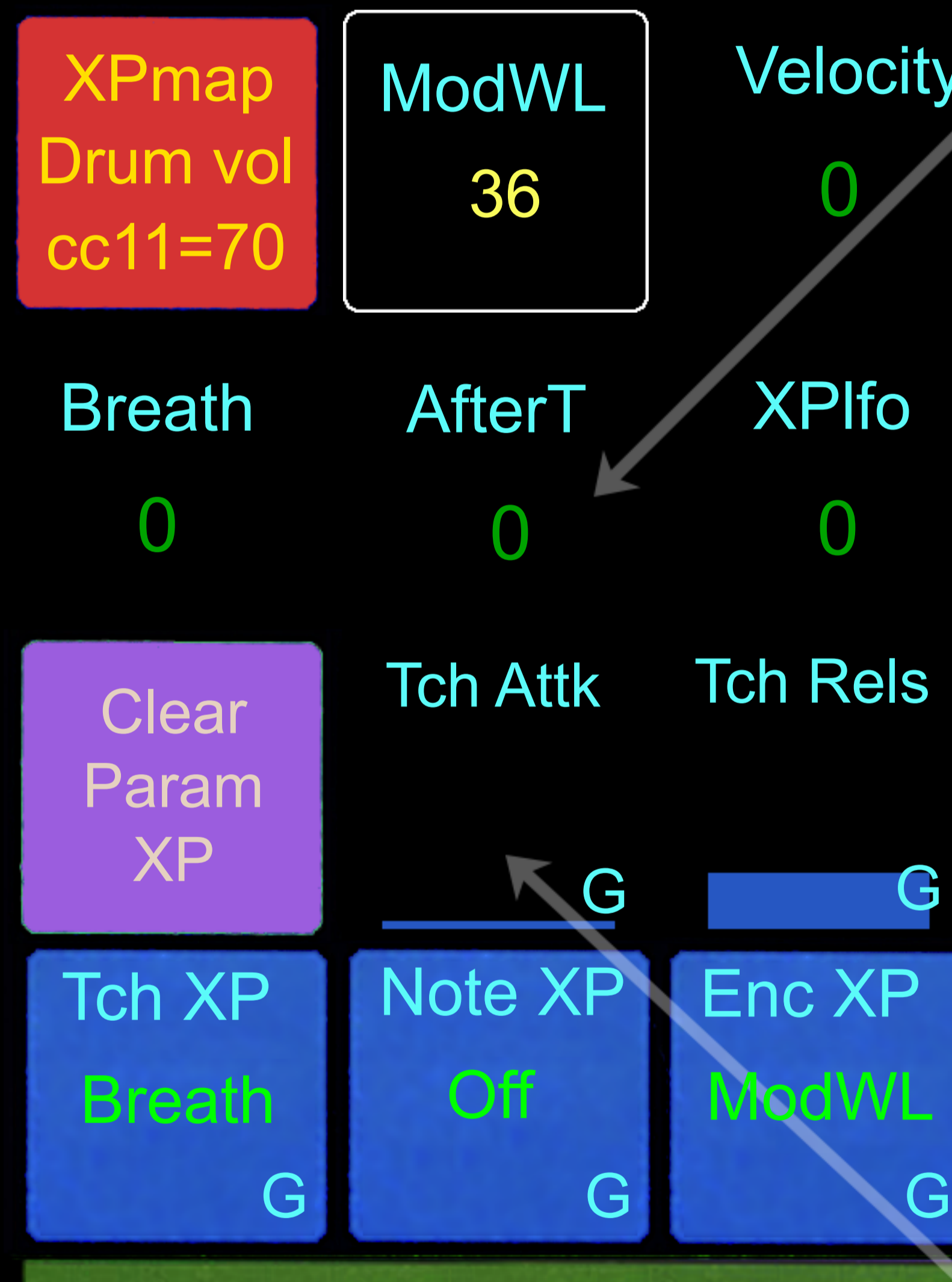

Modblock W1 / W2 waveforms

Additional descriptions of OSCW and MFO waveforms, and internal drum kits, are available in the GND-1T MIDI reference

LFO 1/2 rate waveforms*

TRI	triangle
SQR	square
P75	75% high pulse
P25	25% high pulse
FALL	falling saw
RISE	rising saw
pwmQ3	3-step pwm
pwmQ4	4-step pwm
pwmQ5	5-step pwm
RND	random at lfo rate
8R	8-value random
6R	6-value random
SRD	smoothed random

ENVELOPE waves

ENV	ENV (AHDSR or RUN modified, Page 25)
INV	1-ENV

SLFO and CFO 1/2 rate waveforms*

SLFOx	slow triangle
Sfox 10	10% high Pulse
Sfox 25	25% high pulse
Sfox 50	50% high pulse
Sfox 90	90% high pulse
Sfox rp	random PW
Sfox r	random at SLFO rate
Clfox	chaotic LF oscillator
Cfox 10	approx 10% high
Cfox 25	approx 25% high
Cfox 50	approx 50% high
Cfox 90	approx 90% high
Cfox r	random at CLFO rate

Loop rate waveforms

LP 10	10% high Pulse
LP 50	50% high Pulse
LP rnd	random at loop rate
Other	
oscEnv	OscEnv (Page 8)
Drum	Current Drum Note
D rev	reverse order D notes
Fine	0.059463 (semitone)
DC=1	1 (max)
Sfo 1x2	SLFO1 x SLFO2
Sf1x2 T	Sfo 1x2 thresholded at 50%

mfo.lfo*	“Rungler” waveform Samples mfo @ lfo 1 or 2 rate <small>* new to FW 241211</small>
----------	--

* For these waveforms W1 modulators are derived from LFO 1, SLFO 1, and CFO 1 rates, and W2 from LFO 2, SLFO 2, and CFO 2 rates. Remaining waveforms are derived from identical signals for W1 and W2

Trouble Shooting

Hardware

Audio & phones output

The main audio output is 1/4" STEREO and is not designed to support a mono cable. Use a stereo splitter for this.

For large low impedance studio monitor headphones, an external headphone amp is recommended.

USB host port

The host port is designed to power a single keyboard controller.

A known issue occurs with the Arturia Minilab II, which can produce 'stuck notes' when sending fast modwheel touch-slider changes and notes to the host port. Stuck notes can be cleared using Panic Stop (ALT + screen Patch # button).

This can be avoided by using a small unpowered USB hub between the controller and GND-1T.

Touch screen

For optimal viewing, an angled stand at about 40 degrees is recommended for desktop use. The screen powers up at max brightness. Hold Param and turn the level out pot to dim it. For a lighter touch screen response use more of your finger nail rather than the flat of your finger.

Software / Patch settings

No sound (any patch)

Check Level out settings, including PF scaler [ALT] + level, and Drum scaler [XPress] + level. (see also SysEx Patch transfer errors below)

No sound (patch specific)

As a circuit bent device, there are multiple ways in which a patch can produce no sound.

A few things to look out for are listed here:

Lower high Gravity/Plasma settings, or apply softB, vary the Glitch control

Check FreezeT XP mapping

Check OscEnv mode (esp. LPfrz modes),

OSCGain level, Post Filter cutoff,

ENV trigger modes (including touch

sensor ENV assignments) and AHDSR

No internal audio drum sounds

Check the USB output mode on the MIX page is not set to D>usb (drums only)

Check the internal Drum Kits are not set to Off

Check D>PF settings. If drums are fully mixed to PF, no direct drum sounds will remain in the mix, and you must use RUN (rather than run Drums only) to activate the (PF and) output ENV

No AUX input sounds

The AUX input is mixed with the raw synth signal prior to the PF and ENV stage. To hear the AUX signal you must therefore activate the synth using RUN or MIDI on notes.

To hear only AUX input without the synth set OSCgain to 0

No or slow modulation responses

Check Xfr mod (BENDS2) and FreezeT XP. Check OscEnv mode for modFrz modes

No Tempo changes

Check LOOP length - short loops that contain a single sound fragment are not affected by Tempo. Check OSCenv for LPfrz modes - Tempo may be higher than decay time allows, effectively locking the LOOP

Touch, Note, or Enc XP controller issues

Check you don't have more than one of these assigned to the same controller (modwheel, breath etc). Touching the metal XPress sensor can produce warbling values due to variable body capacitance. Steady it by using other fingers to touch the GND-1T enclosure

SysEx Patch transfer errors

If you have a SysEx manager that allows MIDI thru, ensure that the thru connection for GND-1T to itself is disabled during SysEx transfers. If sending patches, be sure to send all 6 blocks to avoid the GND-1T staying muted (see MIDI REF)

Manual Morph endpoints not as expected

Make sure all excludes are released using a long press on the main encoder (see P 11). Use revert to restart the loop at the nearest endpoint